

Overview for Contract

Prior to utilizing a contract, the user should read the contract in it's entirety.

DESCRIPTION

Compaction Equipment (Rollers) - PA-DOT Spec'ed

This contract does not allow for piggybacking as the items are all spec'ed to Pennsylvania Department of Transportation (PA-DOT) specifications

CONTRACT INFO

Contract Number & Title	Legacy Contract #2540-06 "Compaction Equipment (Rollers) - PA-DOT Spec'ed"
Number of Suppliers	3
Validity Period	01 April 2007 thru 31 March 2008 (4 Renewal Years Possible)
DGS Point of Contact	Richard Woodworth
Contact Phone #	717-787-4103
Email	rwoodworth@state.pa.us

PRICING HIGHLIGHTS

This contract is of a line item format

Units covered are primarily those as used by PA-DOT

Unit specifications conform with PA-DOT requirements

PROCESS TO PURCHASE

Place purchase order for the equipment in accordance with the contract's terms & conditions

SPECIAL CONTRACT TERMS AND CONDITIONS

1. **CONTRACT SCOPE/OVERVIEW:** This Contract No. will cover the requirements for the Department of Transportation (PA-DOT) for the Roller Equipment as cited in this bid document.
2. **ORDER OF PRECEDENCE:** These Special Contract Terms and Conditions supplement the Standard Contract Terms and Conditions For Statewide Contracts for Supplies. To the extent that these Special Contract Terms and Conditions conflict with the Standard Contract Terms and Conditions For Statewide Contracts for Supplies, these Special Contract Terms and Conditions shall prevail.
3. **TERM OF CONTRACT:** The Contract shall commence on the Effective Date which shall be no earlier than April 1, 2007 and expire on March 31, 2008.
4. **SECURITY:** No security is required for this project.
5. **SPECIFICATIONS:**

- a. PA-DOT SPEC'ED UNITS = All PA-DOT Spec'ed units to be provided will be in accordance (as applicable) with Attachments (#2, #5, #6, & #7 dated December 19, 2006 {KGK}) and Attachments (#3, #4, & #8 dated January 23, 2007 {KGK}), Drawings #EQN-206 "Tailgate Carrier Walk Behind Roller" (1 Page) Revision dated 7-1-98, #EQN-351A "Fast Lube Oil Change System" (2 Pages) dated 8-22-97, and Pennsylvania Commercial Item Description (PCID) #1075, effective date of June 25, 2003 (10 Pages – "General Requirements for Bidding Penn DOT Vehicles/Equipment).

For warranty requirements, see PCID #1075, Section E "General Warranty Requirements", Sub Section 3 "Construction Equipment".

- b. All items provided shall be latest model year only.
 - c. Manufacturer's model number changes/revisions will be acceptable so long as price remains as awarded for that line item. If unable to maintain price, that line item will be terminated from the contract, as well as any renewal periods.
6. **TRAINING:**

Training shall be provided for each piece of equipment purchased by the Department.

Mechanic:

The successful vendor shall provide services of qualified factory trained technicians for not more than 2 training sessions of not more than 4.0 hours at 2 PADOT locations to train personnel for in-depth preventive maintenance, overhaul and review of the proper usage of parts and service manuals, as well as component/system adjustments that need to be monitored at specified service intervals.

Operator:

The successful vendor shall provide services of qualified factory trained technicians for not more than 2 training sessions of not more than 4.0 hours at 2 PADOT locations to train personnel in the proper operation, safety and servicing of the equipment.

The successful vendor shall submit a training plan to the Equipment Division for approval within 45 days after receipt of the Purchase Order. The training plan shall consist of course outline and class schedule.

(CONTRACT)

All training must be completed within 60 days after the dates established in the approved training plan unless an extension is mutually agreed to in writing by the Chief of the Equipment Division.

All training shall be coordinated with the District Equipment Managers, with the exception of Asphalt related training, which must be coordinated with the Statewide Training Coordinator (717) 787-4836, Fax (717) 783-4438.

7. MANUALS:

The successful vendor shall furnish all applicable manuals:

The manuals listed shall be official O.E.M. publications supplemented with technical manuals for all components as published by sub-vendors/manufacturers.

Parts Manual presented must be relative to "all" items utilized to build these units, with appropriate part numbers.

1 – Operator's manual per unit

The following manuals shall be supplied as listed below:

Parts

Service

Engine

Transmission (Automatic or Manual)

Body and Sub-Frame (Parts and Service)

Complete set of manuals for any additional items/equipment added to a piece of equipment.

Manuals may be supplied alone or in any combination as listed below:

Online @ Manufacturers' websites.

Unprotected CD/s that may be installed on PA-DOT's Intranet

Protected CD/s

Paper manuals

Delivery of these manuals shall be completed within a maximum of 90 days after the pilot model is accepted.

8. **DELIVERY:** The contractor must deliver all units within One-Hundred Eighty (180) calendar days after receipt of a purchase order, issued against the contract. It shall be assumed by all parties that the contractor received the purchase order on the third business day following the day on the purchase order, unless the contractor provides credible evidence that the order was received on a later date.
9. **SHIPPING:** Shall be in accordance with normal industry standards and at FOB Destination terms.
10. **MINIMUM ORDER:** The minimum order qualifying for F.O.B. Destination delivered prices shall be one (1) unit. (It is understood that prices bid & awarded are at FOB Destination delivered pricing that includes all delivery, shipping & handling, and set-up charges to the ordering agency's location, as stated in the Purchase Order).

(CONTRACT)

- 11. OPTION FOR SEPARATE COMPETITIVE BIDDING PROCEDURE:** The Department of General Services reserves the right to purchase supplies covered under this Contract through a separate competitive bidding procedure, among the current contractors, whenever the department deems it to be in the best interest of the Commonwealth. The right will generally be exercised only when a specific need for a large quantity of the supply exists or the price offered is significantly lower than the Contract price.

This action, if ever taken, will only be done so under the direction of and control of the Department of General Services.

- 12. OPTION TO EXTEND:** The Department of General Services reserves the right, upon notice to the Contractor, to extend the Contract or any part of the Contract for up to three (3) months upon the same terms and conditions. This will be utilized to prevent a lapse in Contract coverage and only for the time necessary, up to three (3) months, to enter into a new contract.

- 13. OPTION TO RENEW:** The contract or any part of the contract may be renewed for an additional one (1) year term, by mutual agreement between the Commonwealth and the Contractor(s). If the Contract is renewed, the same terms and conditions shall apply. Such renewals shall be limited to three (4) one (1) year terms. (ie. Initial one {1} year period + four {4} one {1} year renewal periods = five {5} years Total).

14. ECONOMIC PRICE ADJUSTMENT:

- a. Base Line: As used in this clause, "Established Price" is understood to be the initial awarded line item pricing in regards to this contracting action. The Contractor(s) warrants that the unit price(s) stated for the contract line items, awarded to it, is/are not in excess of the Contractor's normal commercial pricing, in effect on the date set for opening of bids. All contract prices shall be firm against modification for the first calendar year (365 calendar days) from the effective date of the contract.
- b. Decrease to Contract Price(s): At the end of the first calendar year of the contract (and any renewal period there after), the Contractor shall promptly notify the Department of General Services, Bureau of Purchases, of the amount and the effective date of each decrease in any line item commercial pricing. The decreased price shall apply to all items delivered on or after the effective date of the decrease in the Contractor's established price.
- c. Increase to Contract Price(s): At the end of the first calendar year of the contract (and any renewal period there after), the Contractor may submit a request, in writing, to the Department of General Services, Bureau of Procurement, for price increase. This request must include all applicable valid documentation supporting the Contractor's request for price increase. The Commonwealth reserves the right to accept or reject the requested increase(s). The Commonwealth also reserves the right to cancel the contract. The aggregate of any increases in any contract unit price, under this contract (and any renewal period there after), shall not exceed five (5) percent of the original contract unit price(s).
- d. Acceptance/rejection/cancellation action by the Commonwealth shall occur not later than fifteen (15) business days after receipt by the Department of General Services, Bureau of Procurement of a properly documented request for price increase. Any increase(s), that are accepted, shall become effective not later than thirty (30) calendar days after the expiration of the original fifteen (15) business day period reserved to evaluate the request for increase. The increased contract

(CONTRACT)

unit price(s) shall not apply to quantities that were scheduled for delivery before the effective date of the increased contract unit price(s).

- e. d. Invoicing and Payment Amounts: It shall be understood that orders will be invoiced at the applicable contract price(s) in effect on the date that the order(s) is/are placed.

15. **CONTRACT USAGE REPORTS:** All Contract Awardees will be required to provide contract usage reports to the Commonwealth Buyer of record (Currently Richard Woodworth – See Section #19, below). These reports to be in accordance to the following requirements:

- a. To be in an electronic format (preferably Microsoft Excel)
- b. Provided Quarterly
- c. To include the following data –
 - Ordering Agency (i.e. Transportation; Environmental)
 - Purchase Order Numbers
 - Number of Units on the Purchase Order
 - Brake down of units (to include Contract Line Item Number)
 - Date of Orders
 - Delivery Location of Units

16. **INQUIRIES:** Direct all questions concerning this contract to the commodity specialist:

Richard H. Woodworth (YJ1)
Department of General Services
Bureau of Procurement
Forum Place, 6th Floor
555 Walnut Street
Harrisburg, PA 17101-1914

Telephone: 717-787-4103

FAX: 717-783-6241

E-Mail: rwoodworth@state.pa.us

NOTES AND DATA:

The following questions and answers have been previously asked and answered.

Answers are still current.

(22 February 2007)

Question and Answers are as follows:

QUESTION: "Could you please review the requirement for ROPS/FOPS? ROPS makes perfect sense, but Falling Object Protection? All Mfg's have the roll bar but FOPS is a bit excessive. what is the chance of something falling and hitting them on a highway?"

Just checking the current spec sheets of the competitors on item 024600

Cat CB334E	No FOPS
IR DD34HF	No FOPS
Hamm HD13	No FOPS
Dynapac CC142	No FOPS
Bomag BW135	No FOPS

Could you possibly eliminate the FOPS requirement for these rollers by addendum? The same arguments hold true to all the other roller size classes as well."

ANSWER: PA-DOT has determined that they require ROPS / FOPS where cited in the spec.

QUESTION: "Are the only rollers that are on the list of manufacture that are acceptable to bid?"

ANSWER: The units cited on the "Attachments / Specs" are for reference only. Other Makes/models will be considered so long as they meet the specs shown in the "Attachments / Specs".

QUESTION: "Regarding the above mentioned Roller contract, ... The spec calls for "Instrument Panel shall be fitted with a lockable protective cover. All filler caps shall be lockable or fitted with lockable protective covers and all locks keyed alike". ... machines use a padlock for the vandalism protection package (therefore would have a unique key). Is this acceptable?"

ANSWER: Multiple locks can be utilized so long as all the locking devices can be opened using the same single key.

QUESTION: "Can you please clarify that the costs for items #9 Training and #10 Manuals under the Special Contract Terms & Conditions are to be included in the overall price quoted to PENN DOT?"

ANSWER: The vendor is to include the price of manuals and training as per the contract verbiage into their bid. Each unit is to have the appropriate manuals and training is to be provided.

QUESTION: "In previous bid submissions (2420-20 Wheel Loaders and Backhoe Loaders for example) that require equipment to be painted PENNDOT yellow, reference shade DuPont 6808, user groups have determined that the JCB standard yellow is acceptable.

... JCB Vibromax machines are painted the same color as our other equipment and I am requesting confirmation that JCB standard yellow paint will be an acceptable color for any machines sold to PENNDOT under this contract if JCB is fortunate to be a successful bidder."

ANSWER: The JCB factory standard yellow is acceptable to PennDOT.



All using Agencies of the Commonwealth, Participating Political
Subdivision, Authorities, Private Colleges and Universities

ORIGINAL Page 1 of 3
Contract No. 4600012948
Contract Original Approval Date: 10/02/2007

Purchasing Agent:
Name: Rich Woodworth
Phone: 717-787-4103
Fax: 717 346-3820

Valid from/to: 09/25/2007 - 03/31/2008

Please Deliver To:

 To be determined at the
 time of the Purchase Order
 unless specified below

Your SAP Vendor Number With Us: 304774

Supplier Name/Address:
 VOLVO ROAD MACHINERY INC
 VOLVO CONSTRUCTION EQUIPMENT & SRVS
 621 LOWTHER RD
 LEWISBERRY PA 17339-9527
 Supplier Telephone No: 717-938-1441
 Supplier Fax No.: 717-938-1496

Your Quotation: Date:
 Collective No.:
 Our Quotation:

Payment Terms:
 NET 30

The Commonwealth of Pennsylvania, through the Department of General Services, accepts the submission of the Bidder/Contractor for the awarded item(s) at the price(s) set forth below in accordance with: 1) the RFQ submitted by the Bidder/Contractor, if any; 2) the documents attached to this Contract or incorporated by reference, if any, and 3) the contract terms and conditions stored on the website address at www.dgs.state.pa.us for this type of Contract as of the date of the RFQ, if any, or other solicitation for this Contract, all of which, as appropriate, are incorporated herein by reference. When the Bidder/Contractor receives an order from a Commonwealth agency, the order constitutes the Bidder/Contractor's authority to furnish the item(s) to the agency at the time(s) and place(s) specified in the order. RFQ, as used herein, means Request for Quotations, Invitation for Bids, Invitation to Qualify, or Request for Proposals, as appropriate.

Item	Material/Service Desc	Est Qty	UOM	Net Price	Per Unit	Total
10	293877 COMPACTION EQUIP ROLLER Item Text Roller, Vibratory, Double Drum, Walk Behind PA-DOT Equipment Code #025500, Complete and in accordance with bid document attachment titled "Contract #2540-06 Attachment #2 Page 1 of 1", dated December 19, 2006 (KGK) Make: Ingersoll Rand Model: DX600E	0.00	Each	10,119.00	1 Each	0.00
20	293877 COMPACTION EQUIP ROLLER	0.00	Each	27,800.00	1 Each	0.00

SEE LAST PAGE FOR ESTIMATED
TOTAL VALUE INFORMATION



ORIGINAL Page 2 of 3
Contract No. 4600012948
Contract Original Approval Date: 10/02/2007

Supplier Name:
VOLVO ROAD MACHINERY INC
VOLVO CONSTRUCTION EQUIPMENT & SRVS

Item	Material/Service Desc	Est Qty	UOM	Net Price	Per Unit	Total
	Item Text Roller, Vibratory, Articulated, Self Propelled, 3 Ton Class, with 47" Minimum Drum Width PA-DOT Equipment Code #024560, Complete and in accordance with bid document attachment titled "Contract #2540-06 Attachment #4 Page 1 of 1", dated January 23, 2007 (KGK) Make: Ingersoll Rand Model: DD24					
30	293877 COMPACTION EQUIP ROLLER	0.00	Each	32,597.00	1 Each	0.00
	Item Text Roller, Vibratory, Self Propelled, 4 - 6 Ton Class, with 51 Inch Minimum Drum Width PA-DOT Equipment Code #024600, Complete and in accordance with bid document attachment titled "Contract #2540-06 Attachment #5 Page 1 of 1", dated December 19, 2006 (KGK) Make: Ingersoll Rand Model: DD38HF					
40	293877 COMPACTION EQUIP ROLLER	0.00	Each	58,000.00	1 Each	0.00
	Item Text Roller, Steel Drum, with 66 Inch Minimum Drum Width, Rubber Tire, Articulated Vibratory, Self Propelled 7 Ton Class PA-DOT Equipment Code #025000, Complete and in accordance with bid document attachment titled "Contract #2540-06 Attachment #6 Page 1 of 1", dated December 19, 2006 (KGK) Make: Ingersoll Rand Model: SD70D					
50	293877 COMPACTION EQUIP ROLLER	0.00	Each	49,000.00	1 Each	0.00
	Item Text					





ORIGINAL Page 3 of 3
Contract No. 4600012948
Contract Original Approval Date: 10/02/2007

Supplier Name:
VOLVO ROAD MACHINERY INC
VOLVO CONSTRUCTION EQUIPMENT & SRVS

Item	Material/Service Desc	Est Qty	UOM	Net Price	Per Unit	Total
------	-----------------------	---------	-----	-----------	----------	-------

Roller, Rubber Tired, Self Propelled, 9 Wheel, Straight Frame

PA-DOT Equipment Code #025300, Complete and in accordance with bid document attachment titled "Contract #2540-06 Attachment #8 Page 1 of 2 and Page 2 of 2", dated January 23, 2007 (KGK)

Make: Ingersoll Rand

Model: PT 125

General Requirements for all Items:

Header Text

.
. .
. .
PLEASE NOTE THAT THIS CONTRACT #4600012948 IS REPLACING CONTRACT #4600011743 (AS ORIGINALLY ISSUED TO INGERSOLL RAND EQUIPMENT & SERVICES COMPANY, 621 LOWTHER RD, LEWISBERRY PA 17339-9527) DUE TO CONTRACT ASSIGNMENT TO THE NEW OWNER VOLVO ROAD MACHINERY INC, VOLVO CONSTRUCTION EQUIPMENT & SERVICES, 621 LOWTHER RD, LEWISBERRY PA 17339 (Note: This portion of the Ingersoll Rand company was bought out by Volvo Road Machinery Inc).
No further information for this contract.

Estimated Total Value:
\$ 1,272,000.00
Currency: USD



All using Agencies of the Commonwealth, Participating Political
Subdivision, Authorities, Private Colleges and Universities

REPRINT Page 1 of 2
Contract No. 4600011746
Contract Original Approval Date: 04/23/2007

Purchasing Agent:
Name: Rich Woodworth
Phone: 717-787-4103
Fax: 717 346-3820

Valid from/to: 04/01/2007 - 03/31/2008

Please Deliver To:

 To be determined at the
 time of the Purchase Order
 unless specified below

Your SAP Vendor Number With Us: 150032

Supplier Name/Address:
 STEPHENSON EQUIPMENT INC
 DBA SERVICE SUPPLY CORPORATION
 7201 PAXTON ST
 HARRISBURG PA 17111-5198
 Supplier Telephone No: 717-564-3434-110
 Supplier Fax No.:

Your Quotation: Date:
 Collective No.:
 Our Quotation: 6000132659

Payment Terms:
 NET 30

The Commonwealth of Pennsylvania, through the Department of General Services, accepts the submission of the Bidder/Contractor for the awarded item(s) at the price(s) set forth below in accordance with: 1) the RFQ submitted by the Bidder/Contractor, if any; 2) the documents attached to this Contract or incorporated by reference, if any, and 3) the contract terms and conditions stored on the website address at www.dgs.state.pa.us for this type of Contract as of the date of the RFQ, if any, or other solicitation for this Contract, all of which, as appropriate, are incorporated herein by reference. When the Bidder/Contractor receives an order from a Commonwealth agency, the order constitutes the Bidder/Contractor's authority to furnish the item(s) to the agency at the time(s) and place(s) specified in the order. RFQ, as used herein, means Request for Quotations, Invitation for Bids, Invitation to Qualify, or Request for Proposals, as appropriate.

Item	Material/Service Desc	Est Qty	UOM	Net Price	Per Unit	Total
10	293877 COMPACTION EQUIP ROLLER	0.00	Each	9,720.00	1 Each	0.00
	<p>Item Text Roller, Vibratory, Single Drum, Walk Behind, with Tailgate Hanger</p> <p>PA-DOT Equipment Code #026300, Complete and in accordance with bid document attachment titled "Contract #2540-06 Attachment #2 Page 1 of 1", dated December 19, 2006 (KGK)</p> <p>Make: Multiquip</p> <p>Model: V30-4EH</p> <p>Gas Engine with Electric Start: YES</p>					

SEE LAST PAGE FOR ESTIMATED
TOTAL VALUE INFORMATION



Supplier Name:
 STEPHENSON EQUIPMENT INC
 DBA SERVICE SUPPLY CORPORATION

Item	Material/Service Desc	Est Qty	UOM	Net Price	Per Unit	Total
------	-----------------------	---------	-----	-----------	----------	-------

20	293877 COMPACTION EQUIP ROLLER	0.00	Each	20,680.00	1 Each	0.00
----	--------------------------------------	------	------	-----------	--------	------

Item Text

Roller, Trenching, 31.5 to 35.4 Inch Drum Width, 3200 Pound (LB) to 3500 Pound (LB) Operating Weight, Vibratory, with Diesel Engine

PA-DOT Equipment Code #024095, Complete and in accordance with bid document attachment titled "Contract #2540-06 Attachment #3 Page 1 of 1", dated January 23, 2007 (KGK)

Make: Dynapac

Model: CC800-Diesel

Diesel Engine with Electric Start: YES

General Requirements for all Items:

Header Text

Contractor Point of Contact:

Karen Hardy at 717-648-9490 or Dennis Heller at 717-648-9481

khardy@stephensorequipment.com

dheller@stephensorequipment.com

General Office Phone: 800-325-6455

Exclusion for Agencies Using Federal Assistance Monies:

Does Not meet Federal Disadvantaged Business Enterprise ("DBE") participation requirements as defined in federal law and in regulations set forth in 49 C.F.R. Part 26

No further information for this contract.

Estimated Total Value:
 \$ 122,000.00
 Currency: USD



All using Agencies of the Commonwealth, Participating Political
Subdivision, Authorities, Private Colleges and Universities

REPRINT Page 1 of 2
Contract No. 4600011747
Contract Original Approval Date: 04/23/2007

Purchasing Agent:
Name: Rich Woodworth
Phone: 717-787-4103
Fax: 717 346-3820

Valid from/to: 04/01/2007 - 03/31/2008

Please Deliver To:

To be determined at the
time of the Purchase Order
unless specified below

Your SAP Vendor Number With Us: 118349

Supplier Name/Address:
 GROFF TRACTOR & EQUIPMENT INC
 6779 CARLISLE PIKE
 MECHANICSBURG PA 17050-1712
 USA
 Supplier Telephone No: 717-766-7671
 Supplier Fax No.: 717-766-1580

Your Quotation: Date:
 Collective No.:
 Our Quotation: 6000132663

Payment Terms:
 NET 30

The Commonwealth of Pennsylvania, through the Department of General Services, accepts the submission of the Bidder/Contractor for the awarded item(s) at the price(s) set forth below in accordance with: 1) the RFQ submitted by the Bidder/Contractor, if any; 2) the documents attached to this Contract or incorporated by reference, if any, and 3) the contract terms and conditions stored on the website address at www.dgs.state.pa.us for this type of Contract as of the date of the RFQ, if any, or other solicitation for this Contract, all of which, as appropriate, are incorporated herein by reference. When the Bidder/Contractor receives an order from a Commonwealth agency, the order constitutes the Bidder/Contractor's authority to furnish the item(s) to the agency at the time(s) and place(s) specified in the order. RFQ, as used herein, means Request for Quotations, Invitation for Bids, Invitation to Qualify, or Request for Proposals, as appropriate.

Item	Material/Service Desc	Est Qty	UOM	Net Price	Per Unit	Total
10	293877 COMPACTION EQUIP ROLLER Item Text Roller, Steel Drum, with 66 Inch Minimum Drum Width, Articulated, High Frequency Vibratory, Self Propelled, 10 Ton Class PA-DOT Equipment Code #024900, Complete and in accordance with bid document attachment titled "Contract #2540-06 Attachment #7 Page 1 of 1", dated December 19, 2006 (KGK) Make: Hamm Model: HD90	0.00	Each	81,800.00	1 Each	0.00
20	293877 COMPACTION EQUIP ROLLER	0.00	Each	50,498.00	1 Each	0.00

SEE LAST PAGE FOR ESTIMATED
TOTAL VALUE INFORMATION



REPRINT Page 2 of 2
Contract No. 4600011747
Contract Original Approval Date: 04/23/2007

Supplier Name:
 GROFF TRACTOR & EQUIPMENT INC

Item	Material/Service Desc	Est Qty	UOM	Net Price	Per Unit	Total
------	-----------------------	---------	-----	-----------	----------	-------

Item Text

Roller, Rubber Tired, Self Propelled, 9 Wheel, Articulation

PA-DOT Equipment Code #025100, Complete and in accordance with bid document attachment titled "Contract #2540-06 Attachment #8 Page 1 of 2 and Page 2 of 2", dated January 23, 2007 (KGK)

Make: Bomag

Model: BW11RH

30	293877 COMPACTION EQUIP ROLLER	0.00	Each	52,474.00	1 Each	0.00
----	--------------------------------------	------	------	-----------	--------	------

Item Text

Roller, Rubber Tired, Self Propelled, 9 Wheel, Articulation Asphalt

PA-DOT Equipment Code #025200, Complete and in accordance with bid document attachment titled "Contract #2540-06 Attachment #8 Page 1 of 2 and Page 2 of 2", dated January 23, 2007 (KGK)

Make: Bomag

Model: BW11RH

General Requirements for all Items:

Header Text

Contractor Point of Contact:
 Jim Price (Inside Sales) or Mike Lester (Outside Sales -
 Cell #717-554-6590) at 717-766-7671
 jimprice@grofftractor.com
 mikelester@grofftractor.com

Exclusion for Agencies Using Federal Assistance Monies:
 Does Not meet Federal Disadvantaged Business Enterprise ("DBE") participation requirements as defined in federal law and in regulations set forth in 49 C.F.R. Part 26

No further information for this contract.

Estimated Total Value:
 \$ 483,000.00
 Currency: USD

Manufacturers standard walk-behind roller shall be supplied utilizing the following code/s.

025500 – Roller, Vibratory, Double Drum, Walk Behind
Ref. Wacker RD7H, I-R DX600E, Dynapac LP6500, Vibromax VMD80

025900 – Roller, Vibratory, Double Drum, Walk Behind Articulated

026300 – Roller, Vibratory , Single Drum, Walk Behind With Tailgate Hanger
Ref. Wacker RSS800A, I-R SX170H, Multiquip V30-4E

The following additional items shall be supplied

1. Paint – PENNDOT yellow. Reference DuPont 6808 shade only.
2. Single drum roller shall have a central carrying device per EQN-206.
3. Single drum roller minimum 22inch wide.
4. Single drum roller gas engine with electric start.
5. Double drum roller minimum 25 inch wide.
6. Double drum roller diesel engine with electric start.
7. Automatic brake system incorporated into the drive control for safety.

Manufacturers standard ride on roller shall be supplied utilizing the following code/s.

024090 – Roller, Trenching, 35 inch, 2,900lbs. Vibratory – Gas

024095 – Roller, Trenching, 31 to 35.4 inch drum width, 3,050 LB to 3,500LB
operating weight, Vibratory – Diesel
Ref. Bomag BW90AD, Wacker RD15, Dynapac CC800, I-R DD14

The following additional items shall be supplied

1. Paint – PENNDOT yellow. Reference DuPont 6808 shade only. Platform shall be coated with anti-skid paint. (tape is not acceptable)
2. Engine gas/ diesel with electric start.
3. Drum width 31 inch minimum to 35.4 inch maximum with sprinkler system and scraper/pad.
4. Roller shall have a ROPS system
5. Backup alarm. ECCO 450 shock mounted
6. Warning light – 360* LED low profile
7. Instrument panel shall be fitted with vandalism protection cover and lock. All filler caps shall be lockable and all locks keyed alike.
8. FLOCS system per EQN-351A

Manufacturers standard ride on roller shall be supplied utilizing the following code/s.

024515 – Roller, Vibratory, Self Propelled, 2 Ton class, 39" minimum drum width

024560 – Roller, Vibratory, Articulated, Self Propelled, 3 Ton class 47" minimum drum width.
Ref. Cat CB224E, Bomag BW120-4, Wacker RD27-120, I-R DD24, Sakai SW320,
Dynapac CC122, Vibromax VMT280, Beuthling 350

The following additional items shall be supplied

1. Paint – PENNDOT yellow. Reference DuPont 6808 shade only. Platform shall be coated with anti-skid paint. (tape is not acceptable)
2. Hourmeter – hourmeter shall record only when the engine is running.
3. FLOCS system per EQN-351A
4. Roller shall have a ROPS system
5. Backup alarm. ECCO 450 shock mounted
6. Warning light – 360* LED low profile
7. Fire extinguisher, 5 LB. ABC type rechargeable with vehicle mount and weatherproof cover.
8. A slow moving vehicle sign, bracket and holder shall be supplied
9. Instrument panel shall be fitted with a lockable protective cover. All filler caps shall be lockable or fitted with lockable protective covers and all locks keyed alike.
10. FLOCS system per EQN-351A

Manufacturers standard ride on roller shall be supplied utilizing the following code/s.

024600 – Roller, Vibratory, Self Propelled, (PennDOT 3.5-6 Ton Class), 7,000 LB. minimum to 12,000 LB. maximum operating weight. 51” inch minimum to 57” inch maximum drum width.

Ref. Cat CB334E, Bomag BW135, I-R DD34HF, Dynapac CC142, Vibromax VMT390, Beuthling 400

The following additional items shall be supplied

1. Paint – PENNDOT yellow. Reference DuPont 6808 shade only. Platform shall be coated with anti-skid paint. (tape is not acceptable)
2. Hourmeter – hourmeter shall record only when the engine is running.
3. FLOCS system per EQN-351A
4. ROPS, FOPS and operators seatbelt shall be supplied and installed.
5. Backup alarm. ECCO 450 shock mounted
6. Warning light – 360* LED low profile
7. Fire extinguisher, 5 LB. ABC type rechargeable with vehicle mount and weatherproof cover.
8. A slow moving vehicle sign, bracket and holder shall be supplied
9. Instrument panel shall be fitted with a lockable protective cover. All filler caps shall be lockable or fitted with lockable protective covers and all locks keyed alike.
10. Grab handles shall be coated with anti-skid paint (tape is not acceptable)
11. License plate bracket

December 19, 2006 KGK

Manufacturers standard roller shall be supplied utilizing the following code/s.

025000 – Roller, steel drum 66” minimum drum width, rubber tire, articulated vibratory, self-propelled 7 Ton Class
Ref. Cat CS433E, Bomag BW177D-3, I-R SD70D, Sakai SV400D, Dynapac CA150D, Vibromax VM75D

The following additional items shall be supplied

1. FLOCS system per EQN-351
2. Hourmeter – hourmeter shall record only when the engine is running.
3. Instrument panel shall be fitted with a lockable protective cover. All filler caps shall be lockable or fitted with lockable protective covers and all locks keyed alike.
4. Paint – PENNDOT yellow. Reference DuPont 6808 shade only. Platform shall be coated with anti-skid paint. (tape is not acceptable)
5. Fire extinguisher, 5 LB. ABC type rechargeable with vehicle mount and weatherproof cover.
6. Back-up alarm. ECCO 450 shock mounted.
7. ROPS, FOPS and operators seatbelt shall be supplied and installed.
8. Warning light – 360* LED low profile
9. Tires, manufactures standard Diamond Tread.
10. Slow moving vehicle sign, bracket and holder shall be supplied
11. Grab handles shall be coated with anti-skid paint (tape is not acceptable)
12. License plate bracket

Manufacturers standard roller shall be supplied utilizing the following code/s.

024800 – Roller, steel drum 57” minimum, articulated, high frequency vibratory, self-propelled
7 Ton Class

024900 – Roller, steel drum 66” minimum, articulated, high frequency vibratory, self-propelled
10 Ton Class
Ref. Cat CB534D, Bomag BW266, I-R DD90HF, Sakai SW800, Dynapac CC422VHF

The following additional items shall be supplied

1. FLOCS system per EQN-351
2. Hourmeter – hourmeter shall record only when the engine is running.
3. Instrument panel shall be fitted with a lockable protective cover. All filler caps shall be lockable or fitted with lockable protective covers and all locks keyed alike.
4. Paint – PENNDOT yellow. Reference DuPont 6808 shade only. Platform shall be coated with anti-skid paint. (tape is not acceptable)
5. Fire extinguisher, 5 LB. ABC type rechargeable with vehicle mount and weatherproof cover.
6. Back-up alarm. ECCO 450 shock mounted.
7. ROPS, FOPS and operators seatbelt shall be supplied and installed.
8. Warning light – 360* LED low profile
9. Slow moving vehicle sign, bracket and holder shall be supplied
10. Serrated edge on steps
11. Grab handles shall be coated with anti-skid paint (tape is not acceptable)
12. License plate bracket

Manufacturers standard roller shall be supplied utilizing the following code/s.
7-8 Ton Class

025100 – Roller, Rubber Tired, Self Propelled, 9 Wheel, Articulation.
Ref. Bomag BW11RH, Leeboy Tru-Pac 915

025200 – Roller, Rubber Tired, Self Propelled, 9 Wheel, Articulation Asphalt.
Ref. Bomag BW11RH, Leeboy Tru-Pac 915

025300 – Roller, Rubber Tired, Self Propelled, 9 Wheel, Straight Frame.
Ref. Cat PS150C, I-R PT125, Dynapac CP142, Ferguson SP912

The roller shall be equipped with means of adjusting the wheel load by ballasting, and the ply-rating of the tires shall be such that they will support the maximum operating wheel load at the specified maximum contact pressure.

WEIGHT DISTRIBUTION Must be submitted with the Bid and Pilot Model

This form meets the requirements as outlined for the weight distribution slip (all blanks must be filled in).

Roller Light Weight, no ballast or permanent mounted solid weight or steel shaving boxes. (Bare unit).

Weigh slip requirements to be presented with the pilot model:

Roller only	_____	Front Axle
(Barren Weight)	_____	Rear Axle
	_____	Total

"Roller with ballasts", shall be total weighed by a certified weight master and signed and presented with pilot model.

With water ballast _____ gallon Total _____

With dry sand _____ cu. ft. Total _____

With wet sand _____ cu. ft. Total _____

Using total figures above (water ballast = _____ LBS per wheel compaction effort

Using total figures above (dry sand ballast) = _____ LBS per wheel compaction

Using total figures above (wet sand ballast) = _____ LBS per wheel compaction

Then using from above lbs per wheel

Water _____ GCP per tire

Dry Sand _____ GCP per tire

Wet Sand _____ GCP per tire

The manufacturer shall furnish a certified ground contact pressure chart in 100 LB increments between 2,000 and 3,000 LB wheel loads to reflect the closest 100 LB weight. Chart shall be a weather-resistant decal or metal tag attached to the roller.

Wet weight of sand (120 LBS approximately) per cubic ft. shall be used to calculate weights.

The following additional items shall be supplied

1. FLOCS system per EQN-351
2. Hourmeter – shall record only when the engine is running.
3. Instrument panel shall be fitted with a lockable protective cover. All filler caps shall be lockable or fitted with lockable protective covers and all locks keyed alike.
4. Paint – PENNDOT yellow. Reference DuPont 6808 shade only. Platform shall be coated with anti-skid paint. (tape is not acceptable)
5. Fire extinguisher, 5 LB. ABC type rechargeable with vehicle mount and weatherproof cover.
6. Back-up alarm. ECCO 450 shock mounted.
7. ROPS, FOPS and operators seatbelt shall be supplied and installed.
8. Warning light – 360* LED low profile
9. Slow moving vehicle sign, bracket and holder shall be installed
10. Serrated edge on steps
11. Grab handles shall be coated with anti-skid paint (tape is not acceptable)
12. License plate bracket
13. Rear view mirror
14. Turn signals/4 way flashers front and rear

Applies to 025200 Only

Roller shall be equipped with non-stick tires. Ref: Michelin XLC7.5R
Factory installed skirting to maintain maximum heat at the tires.

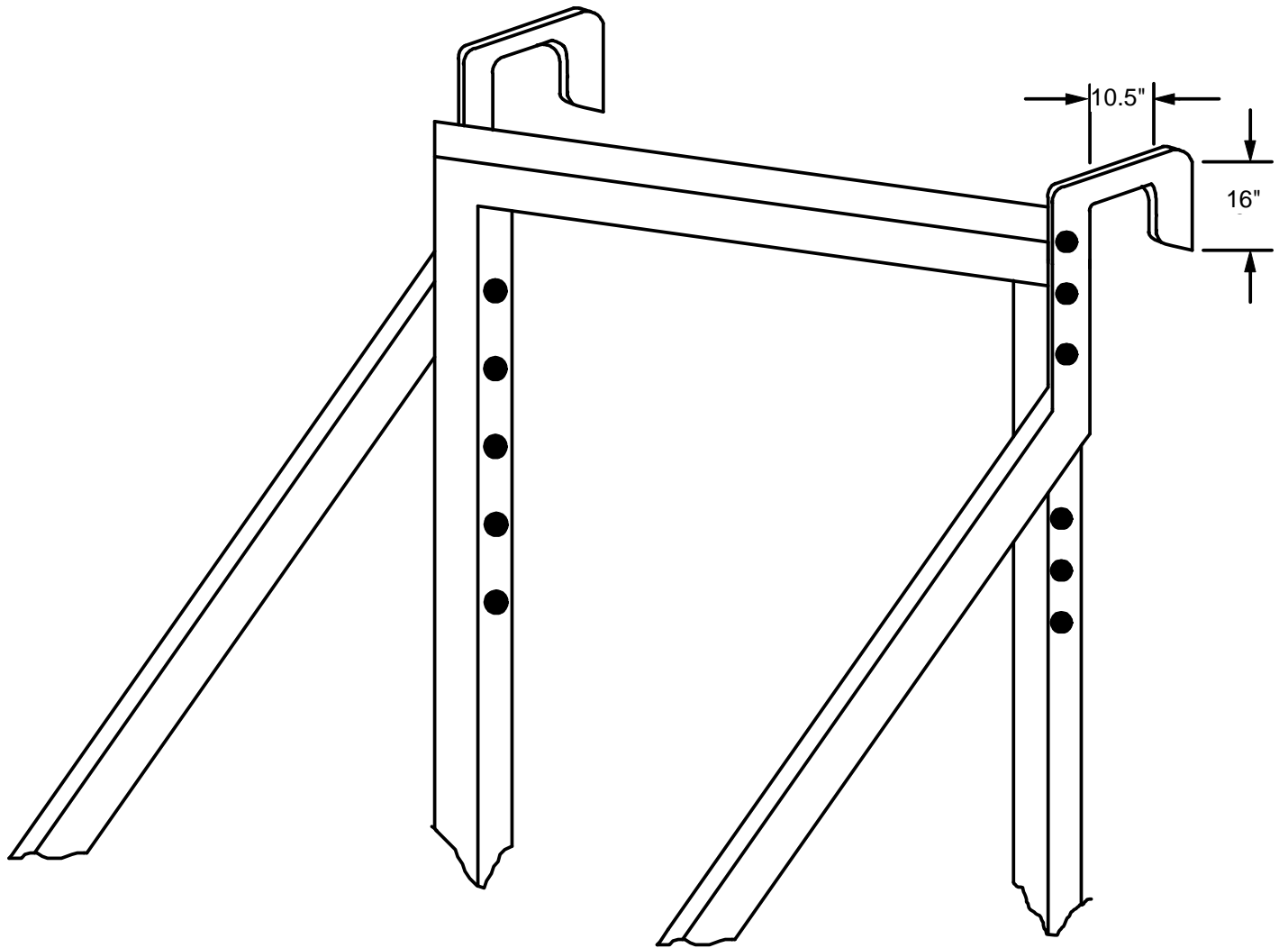

NOTES :

Minimum 0.25" thick steel.
Carrier to be sized according
to applicable roller.

REVISIONS			COMMONWEALTH OF PENNSYLVANIA DEPARTMENT OF TRANSPORTATION		
NO.	DATE		TAILGATE CARRIER WALK BEHIND ROLLER		
1	7-1-98	DJA			
2					
3			DRAWN BY MD	SCALE N / A	MATERIAL
4			CHK'D WHM	DATE 1/4/89	DRW NO.
5					EQN - 206

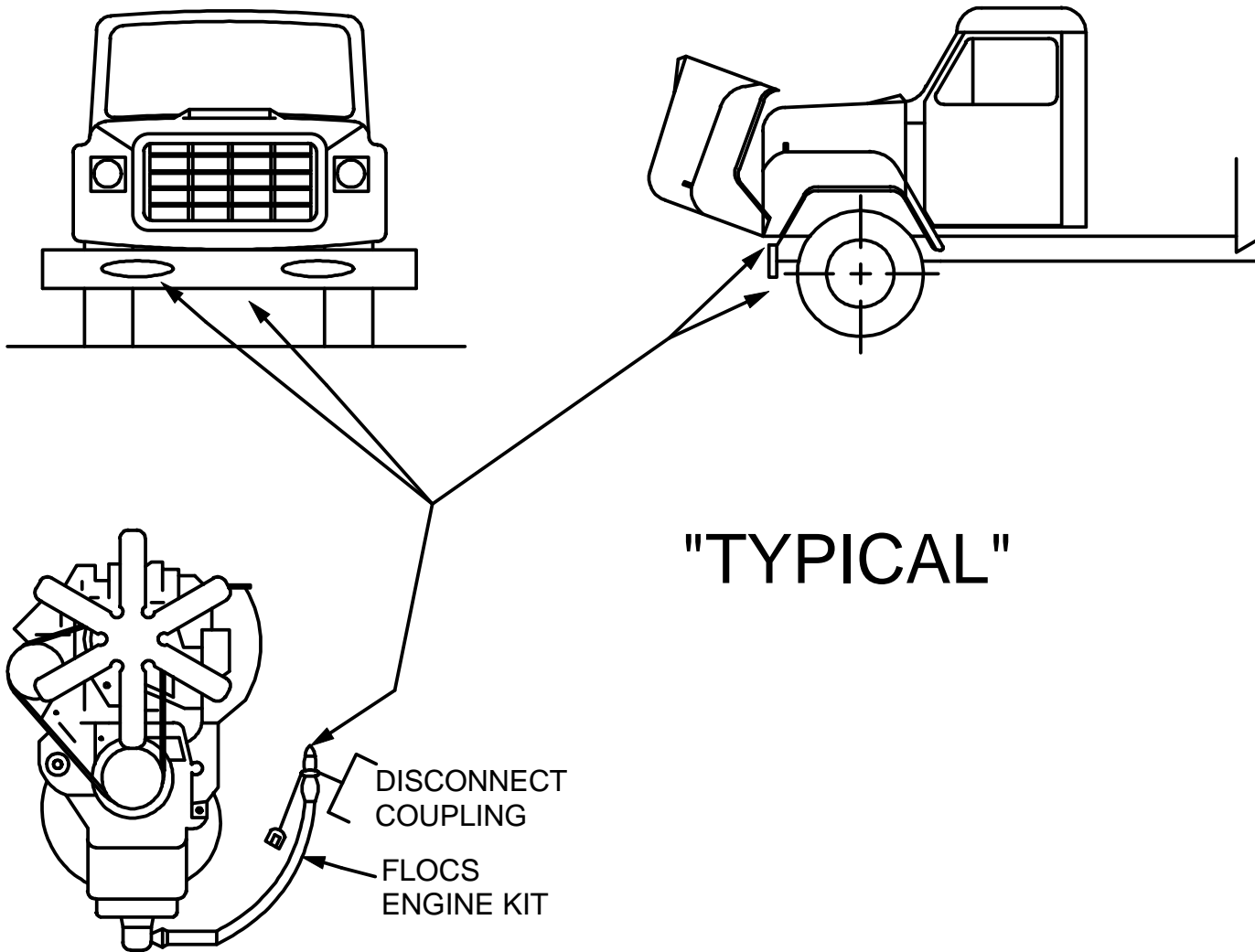

REVISIONS			COMMONWEALTH OF PENNSYLVANIA DEPARTMENT OF TRANSPORTATION		
NO.	DATE	BY	FAST LUBE OIL CHANGE SYSTEM		
1					
2					
3			DRAWN BY DLW	SCALE N / A	MATERIAL
4			CHK'D WHM	DATE 08 / 22 / 97	DRW NO. EQN-351A
5					SHEET 1 OF 2

- 1 - CONTACT AEROQUIP WITH YOUR DRAIN PAN PLUG SIZE
- 2- AEROQUIP DEALER TELEPHONE NUMBERS:

ADVANCED FLUID CONNECTORS.....717-757-1068
 AIR BRAKE & POWER EQUIPMENT CO.....717-622-6188
 AMERICAN BEARING & POWER.....717-569-3291
 GOODALL RUBBER COMPANY.....610-534-2100
 POWER DRIVES INC.....814-833-8181
 R L MILLER INC.....412-833-6800
 R L MILLER INC.....814-456-8900
 SRG/BEVCO.....610-358-3100
 VOTO MANUFACTURERS SALES CO.....814-226-7101

FLOCS SHALL INCLUDE, BUT NOT BE LIMITED TO:

- A. DUST CAP 5657-12
- B. HOSE TO SUIT LENGTH
- C. HOSE FITTING TO SUIT
- D. ADAPTER TO SUIT
- E. HOSE CLAMP #900729-6
- F. BRACKET TO SUIT
- G. COUPLING 5602-12-12S

REVISIONS			COMMONWEALTH OF PENNSYLVANIA DEPARTMENT OF TRANSPORTATION		
NO.	DATE	BY			
1			FAST LUBE OIL CHANGE SYSTEM		
2					
3			DRAWN BY DLW	SCALE N / A	MATERIAL
4			CHK'D WHM	DATE 08 / 22 / 97	DRW NO. EQN-351A
5					SHEET 2 OF 2

Contract Reference Number: 2540-06
Collective Number: CN00025048
SAP Contract Number: See Below
Change Number: #1
Change Effective Date: 04/23/2007

**COMMONWEALTH OF PENNSYLVANIA
DEPARTMENT OF GENERAL SERVICES
HARRISBURG**

For: Department of Transportation
Subject: Compaction Equipment (Rollers – PA-DOT Spec'ed)
Contract Period: Beginning 01 April 2007 and Ending 31 March 2008
Commodity Specialist Name: Richard Woodworth (717-787-4103)

CHANGE SUMMARY: To cancel extention period of former contracts and exercise new contracts

The following contracts are hereby cancelled in their entirety:

- #4600009742 – Ingersoll Rand Equipment & Services Company
- #4600009743 – Stephenson Equipment Inc
- #4600009745 – Eagle Power and Equipment Corp
- #4600010358 – Groff Tractor & Equipment Inc

The new and current contracts are as follows:

- #4600011743 - Ingersoll Rand Equipment & Services Company
- #4600011746 - Stephenson Equipment Inc
- #4600011747 - Groff Tractor & Equipment Inc

ALL OTHER TERMS AND CONDITIONS OF THIS AGREEMENT NOT CHANGED BY THIS CHANGE NOTICE REMAIN AS ORIGINALLY WRITTEN.

Contract Reference Number: 2540-06
Collective Number: CN00025048
SAP Contract Number: See Below
Change Number: #2
Change Effective Date: 09/25/2007

**COMMONWEALTH OF PENNSYLVANIA
DEPARTMENT OF GENERAL SERVICES
HARRISBURG**

For: Department of Transportation
Subject: Compaction Equipment (Rollers – PA-DOT Spec'ed)
Contract Period: Beginning 01 April 2007 and Ending 31 March 2008
Commodity Specialist Name: Richard Woodworth (717-787-4103)

CHANGE SUMMARY: Contract Assignment

Contract #4600011743 with Ingersoll Rand Equipment & Services Company has been assigned to Contract #4600012948 with VOLVO ROAD MACHINERY INC, VOLVO CONSTRUCTION EQUIPMENT & SRVS.

“PLEASE NOTE THAT CONTRACT #4600012948 IS REPLACING CONTRACT #4600011743 (AS ORIGINALLY ISSUED TO INGERSOLL RAND EQUIPMENT & SERVICES COMPANY, 621 LOWTHER RD, LEWISBERRY PA 17339-9527) DUE TO CONTRACT ASSIGNMENT TO THE NEW OWNER VOLVO ROAD MACHINERY INC, VOLVO CONSTRUCTION EQUIPMENT & SERVICES, 621 LOWTHER RD, LEWISBERRY PA 17339 (Note: This portion of the Ingersoll Rand company was bought out by Volvo Road Machinery Inc).”

ALL OTHER TERMS AND CONDITIONS OF THIS AGREEMENT NOT CHANGED BY THIS CHANGE NOTICE REMAIN AS ORIGINALLY WRITTEN.