

Overview for Contract 2310-06 Supp1

Prior to utilizing a contract, the user should read the contract in it's entirety.

CONTRACT DESCRIPTION

Contract provides for the procurement of truck tractors, tandem axle and conventional cab including approved options.

CONTRACT INFO

Material or Service	Material	
Title & Contract # (s)	Truck Tractors and Trailers 2310-06 Supp 1	
Number of Suppliers	1	Pcard enabled: No
Validity Period	2/01/2008 to 1/31/2009	
DGS BOP Point of Contact	Robert L. Isenberg, Sr.	
Contact Phone #	(717) 703-2930	
Email	risenberg@state.pa.us	

PRICING HIGHLIGHTS

No Minimum Order Amount Applicable

Truck tractor available with or without wetline.

Winch option is available for truck tractor.

PROCESS TO ORDER

CONTRACT TYPE- SRM: 4400001944, Supplier: Mack Trucks, Inc.

SPECIFICATION ATTACHMENT A

1. Contract Term.

The Contract shall commence on the Effective Date, which shall be no earlier than February 1, 2008 and expire on January 31, 2009 or until awarded contractor's stock is depleted and cannot be restocked by manufacturer, whichever comes first.

2. Acknowledgement of Order.

The contractor must acknowledge receipt of an order within ten (10) calendar days from the day the purchase order is issued to the contractor. In order to insure timely delivery, the ordering Commonwealth agency and participating local public procurement units should follow up on orders if written acknowledgement is not received within ten (10) calendar days.

Cab shall be made available in all manufacturer's standard available colors, as well as Omaha Orange, 9215 for shade only and PENNDOT yellow, DuPont 6808 for shade only; as specified by the ordering agency

3. Additional Delivery Charges (Participating Local Public Procurement Units ONLY).

Participating local public procurement units may pick up ordered equipment at the awarded contractor's place of business or have the equipment delivered by the contractor for an additional **CHARGE PER VEHICLE, of \$500.00. For Example an order for a Truck Tractor alone would incur a \$500 delivery charge. An order for a trailer alone would incur a \$500 delivery charge. However, an order for a Truck Tractor and Trailer combination would incur a total delivery charge of \$500 paid to the Truck Tractor Supplier.**

4. Pick-up Site.

The contractor must have a site within the confines of the Commonwealth of Pennsylvania for Commonwealth agencies and participating local public procurement units to pick up their vehicle(s), rather than have the vehicle(s) delivered.

5. Contract Implementation

The contractor will work with the CWOPA buyer to provide a complete list of specifications for each awarded vehicle on the Contract.

6. Method of Award.

Attachment A
Truck Tractors & Trailers
Contract 2310-06 Supp 1

Bidders will provide a Contractor 2008 Fixed Vehicle Price for each truck tractor. This fixed dollar amount is defined as the total contractor (dealer) price that will be offered for the vehicle model bid according to the associated minimum specifications. This fixed dollar amount will be inclusive of destination charges and all eligible discounts offered by the contractor and the OEM to CWOPA. This fixed amount will be effective for model year 2008 vehicles or the latest model year vehicles.

This is a Group award contract, the award will be made to the lowest responsible bidder based upon the total extended price per group. All items must be bid within the group to be considered for an award.

NOTE: All line items within a group must indicate a dollar amount. The use of text such as “no charge, free or zero” is unacceptable. The use of a numeric zero is also unacceptable. Failure to properly bid on all lines items within the group shall result in rejection of your bid for that particular group.

7. Clarifications to Legal Document.

- II.3 IFB-009.1 is removed in its entirety. It does not apply to this IFB or any resulting Contract.
- III.3 IFB-007.1 States award will be made through the issuance of a Purchase Order. This is incorrect. Award will be made through the issuance of a contract. No orders may be placed without a Purchase Order issued against the awarded contract.
- V.10 contract-007.01c Refers to the Document as Special Terms and Conditions. The title is “Document” and the referenced Paragraph for Liquidated damages is V.46. The referenced Paragraph for Force Majeure is V.30.
- V.50 References PCID 1067 but incorrectly titles PCID 1067 as GENERAL REQUIREMENTS FOR BIDDING PennDOT VEHICLES/EQUIPMENT. The Contractor must supply the contracted vehicles that are to be delivered to the Commonwealth of Pennsylvania in accordance with PCID 1067, General Requirements for Delivery of Vehicles, which is attached and made a part thereof.
- V.54 Allows for a delivery charge to COSTARS but the amount is listed as \$0.00. The delivery charge allowed shall be \$500.00.
- V.56. is removed in it’s entirety. It does not apply to this IFB or any resulting Contract.



COMMONWEALTH OF PENNSYLVANIA
PENNSYLVANIA COMMERCIAL ITEM DESCRIPTION (PCID)

General Requirements for Delivery of Vehicles

(This item description supersedes PCID 1067, effective July 21, 2006)

PCID NO. 1067

Eff. 7/6/07

The following delivery requirements shall apply to the vehicle as specified by the ordering agency. These requirements are in addition to, but not limited to, the vehicle specification provided as part of the solicitation document. Unless otherwise noted on the request for proposals or invitation for bids, deliveries shall be made to the Department of General Services (DGS), Commonwealth Garage, 22nd and Forster Streets, Harrisburg, Pennsylvania.

NOTE: Deliveries for the Department of Transportation (PennDOT) shall be made to the PennDOT Equipment Division, headquartered in Harrisburg, Pennsylvania. Deliveries for the Pennsylvania State Police (PSP) shall be made to the PSP Transportation Division headquartered in Harrisburg, Pennsylvania.

1.0 GENERAL REQUIREMENTS SECTION

1.1 The vehicle Manufacturer's model name and/or model number shall be indicated on a decal affixed inside the door.

1.2 Standard solid exterior colors with standard interior trim shall be selected after the award is made unless otherwise indicated in the proposal.

1.3 Tire size and type shall be original equipment brand or as indicated in the proposal or specification sheet. Tire inflation monitors shall be supplied as required by Federal Motor Vehicle Safety Standard (FMVSS) 138.

1.4 All vehicles shall be new and of the model year indicated in the proposal.

1.5 All vehicles shall include all genuine parts, accessories and equipment considered standard by the manufacturer for the vehicle offered by the supplier.

1.6 All vehicles shall have a valid PA state inspection sticker and a valid PA emissions inspections sticker (for all vehicles subject to the PA I/M Program). NOTE: New or current model year vehicles with less than 5,000 miles, subject to the PA I/M program, must display a valid PA emissions inspection sticker with an exemption indicator. All Pennsylvania state inspection requirements are the sole responsibility of the supplier.

1.7 All vehicles shall have completed the manufacturers' recommended pre-delivery service.

1.8 All vehicles shall be clean, lubricated, serviced, fuel tank filled to full recommended capacity, all adjustments completed, all mechanical and electrical components fully functional and operational, and the vehicle will be "road ready" for immediate use.

NOTE: Supplier shall not remove the manufacturer's MSRP (Monroney) sticker and/or dealer sticker price prior to delivery. Stickers should be affixed to an interior surface of the vehicle window and legible from outside of the vehicle. Stickers shall be easily removable without any permanent marking left on the glass.

1.9 All vehicles shall have appropriately placed decals or manuals indicating the types of required fuels or lubricants and the capacity of each fluid's reservoir in accordance with the manufacturer's recommendation.

1.10 All vehicles shall have permanent antifreeze in each vehicle to protect it at a level of -35°F. Only a low silicate type anti-freeze will be used for vehicles having diesel engines.

1.11 All vehicles shall be free from all dealer signs/emblems.

1.12 All vehicles shall have all required rust proofing applied to the exterior and underside of the vehicle. No rustproofing compound can be on the personnel compartment's items or the exterior of the body in unsightly or unintended areas.

1.13 All vehicles shall include a copy of the manufacturer's warranty and service policy with all warranty vouchers, certificates and coupons.

1.14 Each vehicle shall include the proper forms to apply for Pennsylvania title and license including the original manufacturer's Statement of Origin signed by the dealer/supplier and notarized. All title papers shall be properly executed and include PennDOT Form MV-1, Application for Title, which shall indicate the owner name and address as follows: **Pennsylvania Department of General Services, 2221 Forster Street, Harrisburg, Pa 17125.***

*VEHICLES DELIVERED TO PA STATE POLICE AND PA DEPT OF TRANSPORTATION SHALL BE TITLED ACCORDINGLY.

1.15 At the time of vehicle delivery, the successful supplier shall furnish an original and three copies of the invoice which shall include the key number, vehicle color and Commonwealth purchase order number and indicate ordering agency.

1.16 The successful supplier shall comply with the manufacturer's warranty, or authorize a qualified dealer in the locality in which the unit is assigned to do whatever is required to comply with the manufacturer's warranty.

1.17 The successful supplier shall submit at least two (2) copies of all service/technical bulletins, recall notices, etc. to the Director, Bureau of Vehicle Management, Department of General Services, 2221 Forster Street, Harrisburg, Pennsylvania 17125. These documents shall be submitted on a continual basis to keep the Bureau of Vehicle Management informed regarding improvements, changes and/or problems concerning Commonwealth owned vehicles and their component parts.

1.18 The Department of General Services, Bureau of Vehicle Management, will inspect all vehicles prior to acceptance. It will be the responsibility of the supplier to remove any vehicle rejected by the Bureau of Vehicle Management within two (2) working days after notification, and return the vehicle to the Commonwealth Garage upon correction of deficiencies. Date in service will be the date the vehicle is accepted by the Commonwealth, not the date of delivery.

1.19 The Commonwealth disclaims any liability for damage to vehicles not unconditionally accepted by the Commonwealth.

1.20 Unless otherwise indicated, all items requested in this specification which are listed in the manufacturer's specification book as standard or optional equipment shall be factory installed and operative. Vehicles delivered to the Commonwealth in a condition considered to be below retail customer acceptance levels will not be accepted. Items which determine this acceptance level shall include, but not be limited to, the general appearance of the interior and exterior of the vehicle for completeness and quality of workmanship, lubrication and fluid levels, with any leaks corrected, mechanical operation of the vehicle and all electrical components operational. Allied equipment specified to be furnished and installed which is not available through the vehicle manufacturer shall conform to the best quality standards known to that particular industry, both product and installation.

1.21 Trucks with snow plows being delivered to the Commonwealth Garage for inspection, are required to have the snow plow stored in the truck bed. Failure to do so will show cause for rejection of inspection.

1.22 All vehicle deliveries shall be coordinated through the DGS Bureau of Vehicle Management. Suppliers shall call (717) 787-4252 for delivery schedule at least 48 hours in advance. When vehicles are purchased by Pennsylvania State Police, the successful supplier shall call (717) 787-1318 (PSP). When vehicles are purchased by Pennsylvania Department of Transportation, the successful supplier shall call (717) 787-2123 (PennDOT) for information regarding invoicing and delivery.

Vehicle Delivery Requirements

PCID NO. 1067

1.23 Vehicle Delivery: Mileage limitations are placed upon vehicles delivered in accordance to these requirements as indicated below. If the mileage upon delivery exceeds these limits, a credit of \$5.00 per mile will be applied against the awarded supplier's purchase order as damages and deducted at time of payment. If the awarded supplier uses a towing device to tow another vehicle to the Commonwealth Garage for delivery, the towing device may not be attached in a way that holes are drilled in the bumpers of the vehicles being towed. Drilling of holes in the vehicle bumpers is not permitted. Any bumper damage caused by a towing device will be replaced by the awarded supplier at no charge to the Commonwealth. If a vehicle is being towed by another vehicle, the vehicle being towed must have the drive shaft disconnected to eliminate unnecessary mileage.

1.23.1 Class 1 to 3 factory completed vehicles: mileage displayed on the vehicle odometer shall not exceed 400 miles.

1.23.2 Class 2 to 5, factory incomplete vehicle: mileage displayed on the vehicle odometer upon delivery with final stage manufacturer certification shall not exceed 800 miles.

1.24 Pennsylvania Clean Vehicles Program Requirement: Supplier is responsible to ensure that all supplied vehicles are compliant with all applicable Title 25 requirements (25 Pa. Code, Chapter 126, Subchapters D or E). This compliance shall be evidenced on the manufacturer's certificate of origin (MCO), or, alternatively, by submission of a completed MV-9. If supplied vehicles are not compliant, they can not be titled in Pennsylvania and the delivering supplier shall be responsible to pick up and return the vehicle by replacing it with a California or "50-state" emissions certified vehicle that is compliant with all Title 25 requirements

2.0 REQUIRED EQUIPMENT SECTION

The following items shall be supplied on all vehicles as **Minimum** required equipment, unless otherwise superceded in the request for proposals or invitation for bids.

2.1 Lug wrench on all trucks and jacks on trucks up to and including 10,000 lbs. GVWR.

2.2 Air conditioning integral with the heater and defrosters.

2.3 Dual electric intermittent windshield wipers.

2.4 The rustproofing shall be factory or locally applied in compliance with Federal Standard 297A. Warranty coupon for five (5) years, at no cost to the Commonwealth, shall be furnished with each vehicle*.

* NOT APPLICABLE IF THE VEHICLE FURNISHED IS FACTORY WARRANTED AGAINST CORROSION FOR NOT LESS THAN 5 YEARS AT NO COST TO THE COMMONWEALTH OF PENNSYLVANIA. WARRANTY INDICATING COMPLIANCE IS REQUIRED WITH EACH VEHICLE.

2.5 Emergency warning triangle kit (on vehicles with GVWR of 10,000 lbs. or higher; aftermarket installation if necessary).

2.6 First aid kit, 10 person with mountable cabinet (on vehicles with GVWR of 10,000 lbs. or higher; aftermarket installation if necessary).

2.7 Fire extinguisher, rechargeable, with vehicle mount, reference 2A:10B:C, 5 pound (on vehicles with GVWR of 10,000 lbs. or higher; aftermarket installation if necessary).

2.8 Powerport.

2.9 Unless otherwise indicated on the purchase order, each vehicle shall be equipped with front and rear license plate holders with a minimum two license plate screws installed.

3.0 MATERIAL MASTERS: N/A

Quality Assurance Specialist: Gerald Grecek, CPPB

Vehicle Delivery Requirements

PCID NO. 1067

Quality Assurance Supervisor: Craig Wolford, CPPB

Division Director: Paul Wolf, C.P.M., CPPB



COMMONWEALTH OF PENNSYLVANIA
PENNSYLVANIA COMMERCIAL ITEM DESCRIPTION (PCID)

GENERAL REQUIREMENTS FOR BIDDING PennDOT VEHICLES/EQUIPMENT

(This item description supersedes PCID No. 1075 eff. 7/31/07)

PCID NO. 1075
Eff. 12/11/07

These General Requirements shall apply to all on-road and off-road vehicles, highway equipment, agricultural equipment and construction equipment, procured for use by the Department of Transportation, Commonwealth of Pennsylvania (PennDOT). These requirements are in addition to any supplemental specifications identified in the invitation for bids. The following shall be considered MINIMUM requirements.

A. STANDARDS, CODES, RULES, REGULATIONS:

1. Each vehicle or unit of equipment shall conform to any and all requirements contained in the Pennsylvania Motor Vehicle Code.
2. Each vehicle or unit of equipment shall comply with all current applicable Federal Motor Vehicle Safety Standards, Federal and Pennsylvania Exhaust Emission and Noise Standards, and EPA and OSHA requirements. The appropriate decals indicating compliance shall be affixed to the vehicle/equipment.
3. Each vehicle or unit of equipment shall be manufactured in accordance with any codes, standards and engineering practices as recommended by the following professional organizations for the specific vehicle/equipment:

American Institute of Steel Construction (AISC)
American National Standards Institute (ANSI)
American Society of Mechanical Engineers (ASME)
American Society for Testing and Materials (ASTM)
American Trucking Association (ATA)
American Welding Society (AWS)
American Wood-Preservers Association (AWPA)
Battery Council International (BCI)
British Standards Institute (BSI): Limits and Fits
Compressed Air and Gas Institute (CAGI)
Industrial Fastener Institute (IFI)
International Standards Organization (ISO)
Joint Industrial Council (JIC)
National Fire Protection Association (NFPA)
National Truck and Equipment Association (NTEA)
Power Crane and Shovel Association (PSCA)
Society of Automotive Engineers (SAE)
Society of Manufacturing Engineers (SME)
Steel Structure Painting Council (SSPC)
Tire and Rim Association (TRA)

B. COMPONENTS, PARTS AND ACCESSORIES:

1. When "No Substitute" components, parts or accessories are designated, only this type of component, part or accessory is acceptable.
2. All equipment and parts furnished shall be of the manufacturer's most current design, shall be included in its most current published list of models in stock and shall satisfy, these specifications.
3. The same model components shall be utilized on all units supplied by the successful bidder under the specifications.
4. All electronic systems associated with the vehicle/equipment shall be properly insulated so as not to not cause any interference with the operation of the vehicle or the land mobile radio communications system, when properly installed in the vehicle.
5. Power systems must be compatible with the engine, transmission, axles, hydraulic system and power steering, etc., in order to meet the requirements specified herein.
6. Vehicles shall meet the maximum gradeability of the manufacturer when loaded to maximum Gross Vehicle Weight Rating ("GVWR") without exceeding the engine manufacturer's recommended maximum revolutions per minute ("RPM") based on maximum net torque.
7. The ratio of the rear axle and transmission shall be geared to maintain a road speed of approximately 65 mph on a level road, when operating at maximum GVWR without exceeding the recommended engine rpm figure. This is not applicable to construction type equipment.

C SITE VISITS:

Prior to submission of its bid, a bidder may contact PennDOT and schedule a site visit to inspect vehicles/equipment (as available) in PennDOT's current inventory in order to further clarify any drawings, pictures and specifications. Units may be available in the field for bidders to inspect at one or more of PennDOT's Maintenance Districts, but the Commonwealth makes no guarantee that any particular vehicle/equipment shall be located at a site convenient to the bidder's place of business. The site visit must be scheduled with the Equipment Division by calling (717) 783-2371. It is the bidder's responsibility to complete the site visit in time to submit a bid. All travel will be at the bidder's expense.

D. ON BOARD VEHICLE/EQUIPMENT REQUIREMENTS:

1. Each vehicle and unit of equipment shall include the proper forms to apply for a Pennsylvania title and license. These forms will include: the original manufacturer's statement of origin signed by the successful bidder and notarized. A detailed invoice listing all equipment, PO number, VIN numbers and price. All title papers shall be properly prepared and executed. The application for title, Form MV-1 shall indicate the name and address exactly as follows: Pa. Dept. of Transportation, Equipment Division, 17th Street and Arsenal Blvd., Harrisburg, PA 17120 (ATTN: Specifications Unit).
2. Trucks and trailers shall be certified to meet or exceed requirements to obtain a Pennsylvania license. For medium and heavy-duty trucks and vans, the GWVR shall be identified in the vehicle's cab as the final complete certification label (minimum rating). The Gross Combined Weight Rating (GCWR) shall be identified by decal in the cab to indicate the approved weight, which can be towed, if applicable.
3. Vehicles designated for on-road/off-road use shall meet the following requirements:
 - a. Shall have a valid Pennsylvania state inspection sticker, if applicable.
 - b. Shall have completed the manufacturers' recommended pre-delivery service.
 - c. Shall have the vehicle manufacturer's model name and model number stated on a decal affixed to the inside of the driver's side door.

- d. Shall be clean, lubricated, serviced, fuel tank filled to full recommended capacity, all adjustments completed, all mechanical and electrical motors and components fully functional and operational, and the vehicle will be “work ready” for immediate use.
- e. Shall have appropriately placed decals indicating the types of required fuels or lubricants and the capacity of each fluid’s reservoir that is required by the vehicle.
- f. Shall have permanent antifreeze in each vehicle to protect it at a level of -35°F. Only a low silicate type anti-freeze will be used for vehicles having diesel engines.
- g. Shall be free from all dealer signs/emblems.
- h. Hydraulic systems shall be compatible with Universal Tractor Fluid (UTF).
- i. Shall include a copy of the manufacturer's warranty and service policy with all warranty vouchers, certificates and coupons as in accordance with section E (GENERAL WARRANTY REQUIREMENTS) as listed below.
- j. Shall have each vehicle and major component identified with a metal identification tag that provides the OEM's name, model number and individual serial number. Tags will be affixed in an accessible and readable position on the item.

The above items are pre-delivery service items, and bidders should not misconstrue these requirements with warranty problems that arise after the Commonwealth accepts the completed unit which complies with the written specifications.

All charges for any of the aforementioned administrative and technical services and equipment are considered minimum acceptable requirements for delivery and shall be included in the bid price.

E. GENERAL WARRANTY REQUIREMENTS

The following warranty requirements are considered minimum unless otherwise stated in the invitation for bids. If the manufacturer's standard warranty exceeds the specified warranty, the manufacturer's standard warranty will apply. Manufacturer's warranty shall be provided in written or electronic form. All warranties will cover all labor and parts replacement, **without deductibles** during the warranty period, except as may be otherwise stated below or in the invitation for bids. This warranty, however, does not include items that must be replaced through ordinary wear and tear, but those parts ordinarily replaced through the servicing program will be replaced as part of the servicing program of equipment/vehicles, if appropriate. Parts replaced under this warranty will be of original equipment manufacturer (OEM) quality or higher. Service to the vehicle/equipment will be at a level to maintain or meet the manufacturer's requirements to sustain the warranty. All warranty policies shall be from the OEM and repairs shall be made at any authorized OEM warranty repair facility. Multiple repair facilities shall be located regionally around the State to support warrantable repairs.

1. **CONSTRUCTION EQUIPMENT:** The construction and agricultural equipment manufacturer's service and warranty program for full machine (“bumper to bumper”) shall be for a minimum of two (2) years or four thousand (4,000) hours whichever first occurs.

2. A. **LIGHT DUTY TRUCKS & VANS (up to 19,500# GVWR):**

The chassis and cab manufacturer's service and warranty program shall be for three (3) years or 36,000 miles (whichever first occurs), including powertrain. A two (2) year, unlimited mileage warranty is acceptable in lieu of a three year, 36,000-mile warranty. The vehicle shall be certified as having a capacity of towing 5,000 pounds minimum without voiding the warranty.

2. B. **MEDIUM DUTY/HEAVY DUTY CAB & CHASSIS (19,501# GVWR or higher):**

The chassis manufacturer's service and warranty program shall be for one (1) year or 12,000 miles (whichever first occurs).

3. ADDITIONAL SPECIFIC WARRANTY ITEMS (Applies to light, medium and heavy duty trucks only)

a. RUST PROOFING WARRANTY

Cabs/cowls shall be warranted for five (5) full years with no mileage or hourly limitations. This will include rusting through or perforation from within. This warranty and service program covers both labor and parts for the full warranty period. Surface rust caused by chip, scratches, or damage caused by PennDOT employees is not covered by this warranty.

b. FRAME RAILS AND CROSSMEMBERS (Chassis)

For medium/heavy duty trucks, frame rails and cross members are warranted for five (5) full years with no mileage or hourly limitations. This warranty covers both parts and labor for the full warranty period. For light duty trucks and vans, the manufacturer's standard frame rail and crossmember warranty is acceptable.

c. FLAT BED WARRANTY

A vehicle's flat bed shall be warranted for three (3) years. This warranty covers both parts and labor for the full warranty period. A decal will be placed on the inside driver's door stating the warranty's terms and the name, address and telephone number of the contact person to initiate warranty claim services.

d. SERVICE/UTILITY BODY AND ASSOCIATED COMPONENTS WARRANTY

Fiberglass bodies will be warranted for five (5) years to include color fading. Steel service and utility bodies shall be warranted for five (5) years against defects and corrosion, including rust through or perforation from within. Surface rust caused by chip, scratches, or damage caused by PennDOT employees is not covered by this warranty. Associated components such as cranes, air compressors, and snowplows shall be covered by manufacturer's standard warranty. Manufacturer's standard warranty shall be provided in written or electronic form.

e. ENGINE AND TRANSMISSION WARRANTY

The engines for all Heavy/Medium Duty equipment/vehicles will be warranted for parts and labor for five (5) years or 150,000 miles (whichever first occurs). The engine warranty will include all items named or included within the valve covers, cylinder heads, block and oil pan. The transmission (automatic/manual) will be fully covered by the warranty and service program for two (2) years and will not be limited by mileage or hours. For light duty trucks and vans, the manufacturer's standard frame engine and transmission warranty is acceptable. Electronic fuel delivery components, electronic control modules and emission control components shall be covered for five (5) years or 100,000 miles whichever first occurs. After treatment Device/DPF shall be warranted for minimum 5 years or 100,000 miles.

f. WARRANTY CARD PROCEDURES

The successful bidder shall complete the warranty card except for the warranty start date. The PennDOT Equipment Division shall inform the successful bidder of the following: model number of vehicle; serial number of vehicle, equipment number, and location assigned; date released to the counties.

F. PILOT MODEL:

PennDOT reserves the right to require the successful bidder to make mutually agreeable arrangements to deliver a “pilot model” for initial inspection. Pilot models(s) shall be delivered to the Department of Transportation, 17th St., & Arsenal Blvd., Harrisburg, PA 17120 for inspection, testing and approval. The remaining units shall not be delivered for inspection, testing and approval until after the pilot model has been accepted by PennDOT. The remaining units shall fully meet the requirements of the specifications and must be indistinguishable from the approved pilot model. Presentation of a pilot model will not be required if the quantity is only one (1) unit. The pilot model must meet all the mechanical requirements of the specifications. PennDOT may field test the equipment to determine if it meets the performance requirements of the specifications. Performance testing results will normally be completed within two (2) weeks of date of delivery. There are administrative items that are required to be presented at the pilot model inspection. It is imperative that all of these items be presented at this time so they are ready for shipment, when the balance of the units are delivered. PennDOT may withhold payment, where deemed necessary, pending receipt of these items. PennDOT disclaims any liability for damage to equipment that has not been unconditionally accepted by the PennDOT.

G. DELIVERY:

Time is of the essence. All units must be delivered within the number of days, specified in the invitation for bids, after receipt of the purchase order by the successful bidder. It shall be assumed by the parties that the successful bidder received the purchase order on the third business day following the date of the purchase order, unless the successful bidder provides credible evidence that the order was received on a later date. Bidders must specify delivery time in their bid. Phrases such as “as required”, “as soon as possible”, or “prompt” have no meaning and may be cause for rejection of the bid. The successful bidder shall deliver **the completed unit(s) at ground level (stacked loads are unacceptable)** to the Equipment Division, 17th Street and Arsenal Blvd. Harrisburg, PA 17120. All deliveries shall be made on a working day between 7:00 AM and 2:30 PM. There is a loading dock at this location; however, any additional unloading cost shall be borne by the successful bidder. The terms of delivery are also controlled by other provisions in the invitation for bids.

The successful bidder shall submit to the PennDOT “on a continuing basis”, all service bulletins and technical letters as regularly issued by a manufacturer to dealers or large fleets. All the relevant information shall be supplied for the unit(s) forwarded to the Commonwealth to inform PennDOT of any improvements, changes and/or problems concerning the unit and its component parts. This information shall be addressed to the Pennsylvania Department of Transportation, Equipment Division, 17th St. & Arsenal Blvd., Harrisburg, PA 17120, ATTN: Specification Unit Chief, Equipment Division. PennDOT reserves the right to have its representative(s) periodically inspect each unit during assembly at the successful bidder’s assembly point.

H. PROCEDURE FOR IMPLEMENTING REPAIRS:

In the event that a breakdown occurs, the repair work is to be performed by the successful bidder of record or his duly authorized representative within the Commonwealth. A copy of the successful bidder's work orders shall be supplied to the PennDOT County Equipment Manager and District Equipment Manager. Repairs assigned to the successful bidder can be performed at the successful bidder’s place of business, at his duly authorized representative’s place of business and, whenever possible, at the county maintenance facility or field locations. If services are to be performed at PennDOT’s county maintenance facilities or in the field, the successful bidder must provide proof of insurance as stated in the contract attachments. County Equipment Managers shall notify the successful bidder or his duly authorized service representatives that the vehicle/equipment is down for component repairs and follow PennDOT standard procedure for handling warranty problems in accordance with the benefits of this warranty. At this time of notification, the location of repair is to be mutually agreed upon based on the most timely and cost effective basis to the Department. All work orders against the warranted repair shall be kept in PennDOT’s Equipment History File at the county maintenance facility.

When repairs are to be performed at the successful bidder's place of business or his duly authorized representative's place of business, transportation of the vehicle/equipment within the Commonwealth of Pennsylvania shall be made by PennDOT. If determined by PennDOT that repairs cannot be handled within the Commonwealth, then transportation to and from the Commonwealth of Pennsylvania shall be the responsibility of the successful bidder.

If mileage costs will be charged to the Department for the diagnosis or repair of a warrantable item, an estimate of these costs shall be given to the County Equipment Manager prior to the repair agreement.

I. LUBRICATION AND COMPONENT INFORMATION:

The successful bidder shall provide lubrication and component information (as applicable) upon request by PennDOT. This information may be provided by copying and completing the sample forms attached to this document, or may be presented on forms prepared by the successful bidder and/or manufacturer. (see attached sample forms – 4 pages).

J. SUCCESSFUL BIDDER'S RIGHTS:

The successful bidder shall have the right to make periodic inspections to ascertain that the maintenance techniques and/or repair procedures are being administered in accordance with the guidelines set forth in this document. Preventive maintenance shall be performed by PennDOT in accordance with the component manufacturer's recommended procedures, or as modified during the contract through supplements. All internal parts of the components shall be the repair responsibility of the successful bidder, except maintenance adjustments.

APPROVALS:

Quality Assurance Specialist: Gerald J. Grecek, CPPB

Quality Assurance Supervisor: Craig E. Wolford, CPPB

Division Director: Paul Wolf, C.P.M., CPPB

Sample Forms (Instruction Sheet)

The Following Documents Shall Be Completed And Emailed / Shipped To

Email: Contact the Automotive Equipment Specialist @ The Equipment Division @ 717-705-2124 (This is an Excel Spread Sheet, a Work Copy will be Emailed to You)

**Mail: Equipment Division
17th & Arsenal Blvd.
Harrisburg, Pa. 17120
Attn: Specifications Division**

Note: These Forms Must Be Delivered to The Equipment Division With The Pilot Model!

**Instructions To Vendor For Completing The Attached Form
(We Would Prefer Having This Completed Electronically)**

Electronic:

- 1. Obtain Work Copy By Calling 717-705-2124**
- 2. All Sections Are to be Filled Out**
- 3. Insert N/A in All Sections That Do Not Apply, Do Not Leave any Sections Blank**
- 4. Manufacturer, Model No. And Part No. Should Reflect The Actual Component Manufacture**
- 5. Warranty Section Should Reflect The Coverage, The Vendor And/Or Equipment (Truck) Manufacturer Will Supply, Not The Component Manufacturer.**

Paper:

- 1. Same As Above, but Type or Print All Information**

LUBE AND COMPONENT SHEET

Equipment # Series		Effective Date						
PO Number		Unit Warranty Period						
Year		Engine Manufacturer						
Make		Engine Model						
Model								
VIN Number								
Vendor		Trans. Manufacturer						
Contact Person		Trans. Model						
Contact Phone Num.		Body Manufacturer						
		Body Number						
Oils & Lubes		Filters	Qty. of Filters	Part Number	Com. Code 2810-	Make	Change Interval	Filters Stocked
Engine Oil		Engine Oil Filter						
		Engine Oil Filter Secondary						
Transmission Oil		Transmission Filter						
		Aux. Trans. Filter						
Fuel		Fuel Filter Primary						
		Fuel Filter Secondary						
Rear Axle / Axles								
Steering Oil		Steering Filter						

Hydraulic Oil		Hydraulic Filter Suction						
		Hydraulic Filter Return						
Coolant		Coolant Filter						
Transfer Case								
Front Axle		Air Filter Primary						
Brake Fluid		Air Filter Secondary						
		Air Compressor Filter						

Description	Manufacturer	Model Number	Part Number	Warranty
Air Compressor				
Air Dryer				
Alternator				
Auto Slack Adjuster				
Auto Lube System				
Axle Front				
Axle Rear				
Battery				
Belt Air Compressor				
Belt Alternator				
Belt Fan				
Belt Power Steering				
Brake Chamber (FRT)				
Brake				

Chamber (REAR)				
Brake Lining (FRT)				
Brake Lining (REAR)				
Clutch Assembly				
Differential				
Dump Body				
Electronic Joysticks				
Engine (AUX)				
Engine (MAIN)				
Fan				
GL 400				
GL 400 Wiring				
Grote Wiring Harness				
Hoist Cylinder				
Hydraulic Pump - Main				
Pump, Fuel				
Pump, Hydraulic Aux.				
Pump, Steering				
Pump, Water				
Radiator				
Rexroth Valve				
Starter				
Steering Gear				
Suspension System				

Tank Fuel Capacity				
Tire Size Front LR				
Tire Size Rear LR				
Transaxle				
Transfer Case				
Transmission				
Wing Plow				



FULLY EXECUTED
Contract Number: 4400001944
Contract Effective Date: 02/12/2008
Valid From: 02/01/2008 To: 01/31/2009

All using Agencies of the Commonwealth, Participating Political
Subdivision, Authorities, Private Colleges and Universities

Purchasing Agent
Name: Isenberg Robert
Phone: 717-703-2930
Fax: 717-783-6241

Your SAP Vendor Number with us: 114765

Supplier Name/Address:
MACK TRUCKS INC
2100 MACK BLVD
ALLENTOWN PA 18105-5000 US

Supplier Phone Number: 610-709-2489

Please Deliver To:

To be determined at
the time of the Purchase Order
unless specified below.

Contract Name:
15 TRUCK TRACTOR, CONV CAB TANDEM

Payment Terms
NET 30

Solicitation No.: 6100002498

Issuance Date: 01/10/2008

Supplier Bid or Proposal No. (if applicable): 6500003199

Solicitation Submission Date: 01/24/2008

This contract is comprised of: The above referenced Solicitation, the Supplier's Bid or Proposal, and any documents attached to this Contract or incorporated by reference.

Item	Material/Service Desc	Qty	UOM	Price	Per Unit	Total
1	TRUCK TRACTOR, WITHOUT WET LINE	0.000	Each	84,436.00	1	0.00
	Valid from 01/24/2008 to 12/31/9999					
	Price(Contract/Bid) 84,436.00 USD 1 EA					
	Item Text					
	TRUCK TRACTOR, CONVENTIONAL CAB, TANDEM, WITHOUT WET LINE, PER DOT SPECIFICATION 033100, SECTION I, PARAGRAPHS A THROUGH D 20.					
	MAKE/MODEL: 2009 MACK CXU613					
2	WET LINE OPTION	0.000	Each	3,364.00	1	0.00
	Valid from 01/24/2008 to 12/31/9999					
	Price(Contract/Bid) 3,364.00 USD 1 EA					

Information:

Supplier's Signature _____

Title _____

Printed Name _____

Date _____



FULLY EXECUTED
Contract Number: 4400001944
Contract Effective Date: 02/12/2008
Valid From: 02/01/2008 To: 01/31/2009

Supplier Name:
MACK TRUCKS INC

Item	Material/Service Desc	Qty	UOM	Price	Per Unit	Total
Item Text WET LINE OPTION FOR TRUCK TRACTOR, PER DOT SPECIFICATION 033200, SECTION I, PARAGRAPH D 22						
3	WINCH OPTION	0.000	Each	8,045.00	1	0.00
	<i>Valid from 01/24/2008 to 12/31/9999</i>					
	Price(Contract/Bid)	8,045.00	USD	1	EA	
Item Text WINCH OPTION FOR TRUCK TRACTOR, PER DOT SPECIFICATION 033100, SECTION I, PARAGRAPH D 21						
4	HEATED WINDSHIELD	0.000	Each	575.00	1	0.00
	<i>Valid from 01/24/2008 to 12/31/9999</i>					
	Price(Contract/Bid)	575.00	USD	1	EA	

Item Text
HEATED WINDSHIELD

General Requirements for all Items:

Header Text
VENDOR INFORMATION
Company Name:Mack Trucks, Inc.
Vendor Number:114765
Contact Person:Danton R. Wickline
Address:2100 Mack Blvd. Allentown PA 18103
Phone Number:610-709-2489
Fax Number:610-709-2895
E-mail Address:#danton.wickline@macktrucks.com
Pick-up Site Address: W.W. Engine, Industrial Blvd. Harrisburg PA
No further information for this Contract

Information:

SPECIFICATIONS

A-56-FQ-C-AW / M-57-CT-F-AX / M-57-CT-Z-AV

033100 thru 034700

TRUCK, TRACTOR, CONVENTIONAL CAB - TANDEM (033100)

TRUCK, TRACTOR, CONVENTIONAL CAB – TANDEM W/WET LINE, 35T (033200)

TRUCK, TRACTOR, CONVENTIONAL CAB W/LOWBOY TANDEM TRAILER, 35T (033300)

TRUCK, TRACTOR, CONVENTIONAL CAB W/LOWBOY TANDEM TRAILER W/W-L, 35T (033500)

TRUCK, TRACTOR, CONVENTIONAL CAB W/LOWBOY TRIAXLE TRAILER, 50T (033700)

TRUCK, TRACTOR, CONVENTIONAL CAB WITH LOWBOY TRIAXLE TRAILER W/W-L, 50T (033900)

TRAILER, LOWBOY, TANDEM AXLE, 35 TON (034100)

TRAILER, LOWBOY, TANDEM AXLE W/W-L, 35 TON (034300)

TRAILER, LOWBOY, TRIAXLE, 50 TON (034500)

TRAILER, LOWBOY, TRIAXLE W/W-L, 50 TON (034700)

INDEX

I. GENERAL TRUCK SPECIFICATIONS (033100, 033200, 033300, 033500, 033700, 033900):

- A. Intent Statement
- B. Weight Distribution
- C. Power Train Overview
- D. Vehicle Components
 - 1. Alarm Backup
 - 2. Axle and Suspension Front
 - 3. Axle and Suspension Rear
 - 4. Brakes
 - 5. Cab
 - 6. Chassis
 - 7. Clutch
 - 8. Drive Line
 - 9. Electrical
 - 10. Engine
 - 11. Engine Accessories
 - 12. Exhaust

SPECIFICATIONS

A-56-FQ-C-AW / M-57-CT-F-AX / M-57-CT-Z-AV

I. GENERAL TRUCK SPECIFICATIONS (033100, 033200, 033300, 033500, 033700, 033900)

(Continued):

D. Vehicle Components (Continued)

13. Fast Lube Oil Change System (FLOCS)
14. Instrumentation
15. Paint
16. Steering
17. Tank - Fuel
18. Tires/Wheels
19. Fifth Wheel
20. Warning Light
21. Winch
22. Wet Line (033200, 033500, 033900, 034300, 034700 only)

II. GENERAL TANDEM TRAILER SPECIFICATIONS (033300, 033500, 034100, 034300):

A. Intent Statement

B. Trailer Components

1. Axle and Suspension
2. Brackets - Side
3. Brakes
4. Dimensions
5. Electric System
6. Engine and Engine Compartment
7. Frame
8. Gooseneck
9. Lashing Rings
10. Platform Size and Construction
11. Access
12. Rustproofing/Paint
13. Rear Frame
14. Tires, Wheels, Rims, Axles
15. Miscellaneous
16. Notes
17. Wet Line (033500, 034300)

SPECIFICATIONS

A-56-FQ-C-AW / M-57-CT-F-AX / M-57-CT-Z-AV

III. GENERAL TRI-AXLE TRAILER SPECIFICATIONS (033700, 033900, 034500, 034700):

- A. Intent Statement
- B. Trailer Components
 - 1. Axle and Suspension
 - 2. Brackets - Side
 - 3. Brakes
 - 4. Dimensions
 - 5. Electric System
 - 6. Engine and Engine Compartment
 - 7. Frame
 - 8. Gooseneck
 - 9. Lashing Rings
 - 10. Platform Size and Construction
 - 11. Access
 - 12. Rustproofing & Paint
 - 13. Rear Frame
 - 14. Tires, Wheels, Rims, Axles
 - 15. Miscellaneous
 - 16. Notes
 - 17. Wet Line (033900, 034700)

IV. DRAWINGS:

V. MANUALS:

VI. TRAINING:

VII. WARRANTY:

SPECIFICATIONS

A-56-FQ-C-AW / M-57-CT-F-AX / M-57-CT-Z-AV

I. GENERAL TRUCK SPECIFICATIONS (033100, 033200, 033300, 033500, 033700, 033900):
(Tractor only)

A. INTENT STATEMENT:

The purpose of these specifications is to describe a truck/tractor, conventional cab, with a tandem drive rear axle to be used for heavy hauling of varied road and construction machinery on and off the road. The truck shall be equipped to accommodate a drop deck, slope front, trailer.

It shall be the sole responsibility of the successful vendor to ensure compatibility with the Department's trailer(s), and not surpassing any overall length ruling and meeting all bridge formulas. This is of particular note to those orders received for tractors without trailers. The vendor shall, prior to bid, inspect the Department's trailer(s) to ensure this compatibility. For trailer location contact the Equipment Division at 717-783-2371.

NOTE: Pennsylvania Department of General Services, PCID No. 1075, "*General Requirements for Bidding PENNDOT Vehicles/Equipment*", most current version effective at the time and date of bid opening, is included as a part of this specification. PCID No. 1075 may be reviewed and downloaded from the Department of General Services website, <http://www.dgs.state.pa.us>.

Delivery as required per Department of General Service PCID NO. 1075 Section E. 1. All units must be delivered within **300** days after receipt of the purchase order by the successful bidder.

B. WEIGHT DISTRIBUTION:

Weight Slip shall be provided with the pilot model for the unit supplied.

It is understood that the components specified are minimum and if the truck manufacturer's Engineering Department recommends or deems necessary, due to their particular weight distribution, a larger component or a larger GAWR totally, the burden of responsibility is hereby placed upon the Manufacturer's Engineering Department to supply a unit that is totally engineered.

1. Frame
2. Axle
3. Tires
4. Steering unit and components
5. Rims
6. Suspension
7. Brakes
8. Any other items as required

The dynamic and static loads created by the unit, plus operational stresses, must be reviewed to ensure the Commonwealth of a properly designed/engineered unit.

The vehicle shall be certified for **80,000** LB Gross Vehicle Weight Rating (GVWR). The GVWR shall be identified in the cab or on the door as the final complete certification label (minimum rating).

SPECIFICATIONS

A-56-FQ-C-AW / M-57-CT-F-AX / M-57-CT-Z-AV

I. GENERAL TRUCK SPECIFICATIONS (033100, 033200, 033300, 033500, 033700, 033900):
(Continued)

C. POWER TRAIN OVERVIEW:

ENGINE, DIESEL– MIN. 450 HP AT GOVERNED RPM, MIN. PEAK TORQUE OF
1550 LB/FT TORQUE, MIN 12.0 LITER

TRANSMISSION – 13 SPEED

EATON RTLO – 16913A
MACK – T313

REAR AXLE – DANA DD463P or D46-170HP
MACK S 440 OR S462
MERITOR RT46 -160 – P

NOTE: All rear axles must provide axle shafts with a minimum diameter of 2.19
inch at the spline.

NOTE: Lubricants for front axle hubs and differentials, manual transmissions, transfer cases and
all rear differentials shall met or exceed all appropriate MIL AND SAE specifications for
synthetic lubricants and shall have all plugs identified as synthetic or painted red.
(The OEM shall provide written exemption if synthetic oil is not installed.)

D. VEHICLE COMPONENTS:

1. ALARM - BACKUP:

ECCO 450 shock mounted alarm.

2. AXLE AND SUSPENSION FRONT:

12,000 LB capacity GAWR.
Standard suspension 12,000 LB.
Front Shock absorbers.
Sufficient tire clearance at maximum turning angles.
Complete plug type window hubcap and oil seal assembly, or approved equal.
Each unit shall have the front end aligned
The front axle, tie rods and drag links shall have grease zerks installed.
Set back axle is acceptable.

NOTE: Above GAWR minimum relative to Engineering Department weight distribution chart.

SPECIFICATIONS

A-56-FQ-C-AW / M-57-CT-F-AX / M-57-CT-Z-AV

I. GENERAL TRUCK SPECIFICATIONS (033100, 033200, 033300, 033500, 033700, 033900):
(Continued)

D. VEHICLE COMPONENTS: (Continued)

3. AXLE AND SUSPENSION REAR:

There shall be an inter-axle differential lock that is manually cab controlled.

STEMCO Guardian rear wheel seals or approved equal.

Suspension shall be tailored to axle loads and shall be adequate to sustain maximum GCW without overload or permanent set. REF: Hendrickson model 460 with extended leaf, or 46,000 LB air ride.

NOTE: Rear axle ratio's selection will be made after the award and may be a mix of ratios as required. The successful vendor/manufacturer shall present three (3) computer runs showing 3 most likely candidates for consideration for a speed range up to 65 MPH maximum. This information shall be presented at the pre-build meeting.

4. BRAKES:

ABS, with cab-mounted diagnostic switch.

Full air in compliance with the most current FMVSS requirements.

Air compressor with dash-mounted gauge(s).

Buzzer-type. Low air pressure indicator.

Spring-type, rear wheel parking brake, MGM 30/30 chambers.

Rear brake chambers mounted to provide maximum road clearance.

Automatic air reservoir drain valve. (DV-2 drain valves with heater) on first (wet) tank all other reservoirs shall have manual drain valves. Air dryer: with heater, inboard mounted, Ref: Haldex DRYest or Bendix AD-IP

Hand-operated trailer brake control valve.

Tractor protection valve (breakaway valve) with dash-mounted manual control.

Semi-trailer brake hoses, coil type, connectors, and hangers (mounted back of cab). There shall be Bendix dummy couplings (service/emergency) placed in close proximity to the retractor to allow the stowage of the unused hose coupling. Hoses and couplings shall be color coded.

16.5 inch x 7 inch foundation brakes, rear brakes.

"S" cam single anchor pin or quick change type, double-anchor pin. (No substitute).

16.5 inch x 5 inch or 6.5 inch x 6 inch "S" cam foundation steer axle brake or a power front disc brake system providing equal performance including quick change type single or double anchor pin if drum type brakes are furnished.

Automatic slack adjusters, shall be clearance sensing type.

SPECIFICATIONS

A-56-FQ-C-AW / M-57-CT-F-AX / M-57-CT-Z-AV

I. GENERAL TRUCK SPECIFICATIONS (033100, 033200, 033300, 033500, 033700, 033900):
(Continued)

D. VEHICLE COMPONENTS: (Continued)

5. CAB: (Steel or Aluminum)

Conventional cab.

Bumper to Back of Cab (BBC) dimension excluding frame extension, must be compatible with trailer.

Hood: Fiberglass or aluminum tilting. Fenders shall be part of tilting hood.

Cab shall have an air suspension system, REF: Link Manufacturing Co., Cab Mate, telephone (712) 324-4520 or OEM cab suspension system.

Air Conditioning: Highest output available as OEM option.

Air deflector: Clear or smoked, hood-mounted. Deflector manufacturer's standard full width for the truck model. Access to front-end hood-tilt handle shall not be blocked. Extra handle acceptable, Ref: DEFLECT-SHIELD Corp., telephone: 1-800-247-2440.

Seats: Driver's seat shall be high-back, adjustable BOSTROM Air 915 Series with lumbar support or National 195 Series, with lumbar support or DuraForm Air Command Series (fabri-form cushions with lumbar support), with body cloth insert and three-point retractable seat belt. A bellow-type protective skirt shall cover the seat suspension mechanism. No substitute on seat reference. Color coordinated with cab interior. Driver's seat shall have twin fold down arm rests.

Passenger seat: With three-point, retractable seat belt. Non-suspension type. Ref: Manufacturer's high-back. Color coordinated.

Deluxe fresh air hot water heater and defroster.

Windshield: One (1) or two (2) piece construction AST-1, tinted.

Dual interior sun visors.

Exterior windshield sun shade (visor).

Dual windshield wipers: Shall be the heaviest wipers, arms and linkages available. They shall be two (2) speed, intermittent.

Washer tank: Minimum capacity two (2) quarts of washer fluid. Shall be filled with an anti-freeze type solvent.

Mirror(s): Lanescan right side controlled powered mirror to improve viewing of driver's right side vision.

Product is to have a dash mounted Lanescan control box with controls to adjust for home (center) position of right side mirror, a Lanescan knob to adjust for amount of Lanescan mirror movement, a manual & automatic position control, a right to left manual operation button and a control box mounted Lanescan button. The device must also have a gear shift mounted driver controlled button to remotely operate the Lanescan mirror to the driver's variable set point.

Reference: Lanescan automatic remote control mirror or approved equal. Part LSCR716MKIT with spot mirrors.

Left side mirror shall be heated 7 inch X 16 inch stainless steel non-powered and matching design of Lanescan right side mirror head. Left mirror head should also have mounting points at bottom of mirror to accept a bracket to mount a heated rectangular 5.5 inch H X 8.5 inch W with Manufactures standard spot mirror is to be stainless steel and heated with wires attaching directly to heater wires of flat glass mirror using provided connectors.

Wiring for all mirrors should have plugs to allow for replacement of mirrors from Exterior of truck body.

Heater switch will be provided to allow easy reach of driver to operate mirror heaters on either side.

SPECIFICATIONS

A-56-FQ-C-AW / M-57-CT-F-AX / M-57-CT-Z-AV

I. GENERAL TRUCK SPECIFICATIONS (033100, 033200, 033300, 033500, 033700, 033900):
(Continued)

D. VEHICLE COMPONENTS: (Continued)

5. CAB: (Steel or Aluminum) (Continued)

There shall be a heated blind-spot elimination mirror mounted on the right front fender and it shall be eight (8) inch minimum, diameter stainless steel or aluminum head with mirror. Mirror shall be a conventional convex mirror and shall not be of the half-round cross view type. All arm(s) and hardware shall also be stainless steel. Fender type washers stainless or aluminum, with rubber pads to be placed on both sides of the fender shall be included. Pedestal system shall be single, double or triple mounting assemblies (stainless steel or aluminum). Mirror shall be mounted in rubber or vinyl. Grote (800-628-0809)

Drivers and passenger entrance steps: Shall be aluminum, serrated. The outer step edge must be serrated in lieu of plain. (Overlay is not acceptable).

Step design material must be the same both left and right side.

Ref: Bustin No. NST4 full size, Ohio Grating No. JA21195G4 serrated, IKG. Industries Type B54 or Mack Part # 85QM423OM4

Top of the first step shall be approximately 21 inch above the ground. There shall be Bustin type material to allow for walking and standing aft of the cab, forward of the fifth wheel.

CB power connections, 1 pair, at the dash per EQN-78.

Grab handles (2): Shall be furnished to provide "Optimum safety" for entering the truck cab. Manufactures standard or aftermarket. Non-skid paint or rubber may be utilized, (non-skid tape is unacceptable).

Ref: Non skid paint, Gamma Laboratories (Tel. 304-489-2828.)

There shall be a beverage holder within reach of the driver's seat.

Air horn(s): With protective cover(s).

All controls and knobs shall be property identified.

The cab floor covering shall be heavy duty rubber with closed cell rubber or heavy felt backing.

The engine components facing wheel areas, on both sides, shall be shielded.

Inside dome light.

Radio: AM/FM with weather band

Cruise control

Telescopic and tilt steering, wheel diameter shall be 18 inch (approx.).

Fire extinguisher rechargeable with vehicle mount. Mounted for easy and quick access. 2A:l0BC:C.

There shall be an emergency triangle warning kit and it shall be secured in the cab.

There shall be a first-aid kit mounted in the cab. Ref: AW Direct, Part No. FA-10 or equal.

SPECIFICATIONS

A-56-FQ-C-AW / M-57-CT-F-AX / M-57-CT-Z-AV

I. GENERAL TRUCK SPECIFICATIONS (033100, 033200, 033300, 033500, 033700, 033900):
(Continued)

D. VEHICLE COMPONENTS: (Continued)

6. CHASSIS:

80,000 LB GCWR manufacturer's rating.

Heavy-duty front bumper.

Two (2) frame mounted tow hooks or tow eyes.

Frame shall have a minimum resisting bending moment of 1,900,000 LB per side rail min.

24 inch x 34 inch deck plate aluminum, Bustin Type (NST4), open grating on frame behind cab. Ref: material per I.D.5 The frame must not interfere with the trailer gooseneck in the "break-down" mode, fifth wheel placed 6 inch forward of rear axle center, see I.D.19 for fifth wheel location.

Tapered frame rails, as necessary, shall be included.

CA shall be as short as possible and still accommodate all specified components.

There shall be a centralized on board NLGI #2 chassis lubrication system. The system shall have a fault light that will illuminate when there is a malfunction with the system. The light shall be cab-mounted so the operator can visually monitor the system. Steel tubing (hard pipe), shall be utilized where/when ever possible and practical. Reference: EQN-160.

Approved grease manufacturers:

Grease Jockey

Groeneveld Lube System

Lincoln Lube System

Vogel Lubrication Inc.

JA Lube System

Farval Grease System

7. CLUTCH: (if applicable)

Externally lubricated and torque limiting clutch brake.

Clutch shall be capable of 100 ft/lb. above peak engine torque.

Clutch adjustment shall be set to specifications prior to delivery to the Department.

There shall be a neutral safety device to ensure that the vehicle cannot be started in gear.

Note: The transmission-input shaft shall be 2 inch spline. Dampened driven disc.

8. DRIVE LINE:

Main drive line and interaxle driveline shall be: SPICER Life Series.

Heavy-duty driveline shall be engineered and be compatible to engine, drive train and transmission torque.

Heavy-duty center bearing, if required, with due consideration to drive shaft angles, length, location, proper bolting based upon engine and transmission selection.

"Factory balanced" greasable, (1 zerk minimum).

SPECIFICATIONS

A-56-FQ-C-AW / M-57-CT-F-AX / M-57-CT-Z-AV

I. GENERAL TRUCK SPECIFICATIONS (033100, 033200, 033300, 033500, 033700, 033900):
(Continued)

D. VEHICLE COMPONENTS: (Continued)

9. ELECTRICAL:

All copper system, negative ground.

Batteries: Three (3) or four (4), heavy-duty, 12-volt, maintenance-free, BCI Group Size 31, with stud-type posts and anti-corrosion treatment on each terminal. 2250 total cold cranking amperes (CCA) at 0 degrees F min.

640 minutes of total reserve capacity at 80 degrees F as per SAE.

Battery Mounting: Shall include the following:

- a. Thick rubber shock pad under the battery(s).
- b. Box with cover. Cover shall be constructed of fiberglass, poly or aluminum (if aluminum, there shall be an insulating liner).
- c. Mounting bolts grade-8 with self-locking nuts.

Cables shall conform to RCC Practice 105 with "sealed" terminal ends for stud-type battery posts.

Electrical system: Circuit-breaker-equipped, in easily accessible location, weatherproof. Fuses acceptable in circuit so identified by manufacturer as safety factor. Any fuse or circuit breaker liable to be damaged during truck operation shall have an easily removable protective cover.

Alternator: 90 A, minimum, brushless, high performance, solid state.

Starter motor: With thermal overcrank protection and high torque capacity. Suitable for the diesel engines offered as per starter manufacturer's recommendation. Battery cable from battery negative terminal to starter motor.

Alternator and starter mounting bolts: Grade 8.

Note: All lights shall be L.E.D. for tractor and trailer.

Parking lights front and rear. Five clearance lights.

Hazard lights, stop and tail lights, back-up lights.

Halogen head lights. (Daytime Running Lights)

All exposed junctions: Waterproof and sealed against salt. External splices are not allowed. There shall be no splices made outside of a weatherproof box.

There shall be a connector box on the rear frame per EQN-81A.

If an audible alarm is supplied for 4 ways and turn signals, it shall have on/of capability.

Charger plug: There shall be an auxiliary plug supplied on the tractor in order to charge the flasher battery on the trailer/s

10. ENGINE:

Replaceable heavy-duty filter(s) and oil filter(s) with legible OEM part numbers as recommended by the manufacturer.

The largest factory available engine cooling capacity compatible with engines referenced and transmission referenced.

Radiator core and shell shall be of heavy-duty design.

Radiator capacity for continuous high engine output under extreme temperatures and/or operating conditions due to prolonged operations in low gears and low speeds.

The oil dipstick must have a tubing and dipstick with sufficient length to provide reasonable access for checking the oil level.

SPECIFICATIONS

A-56-FQ-C-AW / M-57-CT-F-AX / M-57-CT-Z-AV

I. GENERAL TRUCK SPECIFICATIONS (033100, 033200, 033300, 033500, 033700, 033900):
(Continued)

D. VEHICLE COMPONENTS: (Continued)

11. ENGINE ACCESSORIES:

Immersion type in block engine heater for cooling system with waterproof flush-mounted plug in front sheet metal, 115V prong plug.

Water filter. As recommended by engine manufacturer.

Heavy duty air cleaner. Capacity adequate for maximum performance to the engine and dash-mounted air restriction indicator graduated locking type.

Bug screen-covering radiator.

Diesel fuel filter - DAVCO 382 (as a single filtration unit, return fuel heat).

Engine brake: minimum 2 stage, full engine compression brake, Ref: JACOBS.

Magnetic drain plug.

Governor set at manufacturer's recommended maximum RPM.

12. EXHAUST:

Aluminized or stainless steel, under-cab DPF configuration with vertical exhaust stack.

Tailpipe with rain cap or elbow.

The tailpipe shall have a shield to protect personnel from burns when entering or exiting cab. Protector shall be non-rust material.

13. FAST LUBE OIL CHANGE SYSTEM (FLOCS):

This system will be installed with all fittings, brackets, clamps and hoses as per attached drawing EQN-351A. The system will be compatible with all fittings presently used by the Department. The final placement of the male half of the snap coupler on the equipment will be decided at the pre-build meeting. Ref: Aeroquip or prior approved equal.

14. INSTRUMENTATION:

Oil pressure gauge.

Water temperature gauge.

Air pressure gauge.

Intake manifold pressure gauge.

Fuel gauge.

Speedometer.

Parking brake indicator with light.

Tachometer.

Voltmeter.

Hourmeter that records only when the engine is operating.

SPECIFICATIONS

A-56-FQ-C-AW / M-57-CT-F-AX / M-57-CT-Z-AV

I. GENERAL TRUCK SPECIFICATIONS (033100, 033200, 033300, 033500, 033700, 033900):
(Continued)

D. VEHICLE COMPONENTS: (Continued)

15. PAINT:

PENNDOT yellow, Ref. DuPont 6808 for shade only.
All metal surfaces including rims shall be cleaned prior to primer and final painting.
Tractor/trailer shall color match (if sold as a set).
Conspicuity per EQN-127A and EQN-131.

16. STEERING:

Dual integral or single integral type hydraulic power steering.
The pump shall not be the integral filter type unit.
Steering system (e.g. flow, pressure, relief valve etc.) shall be selected considering the full front-GAWR axle loading. Ref: ROSS or SHEPPARD gear assembly .).
Hydraulic supply pump, vane type or roller type supply pump with sufficient oil flow to permit one (1) steering wheel revolution per second with front axle loaded to rated capacity, in a "park" condition.
Power Steering Reservoir, "remote mounted", incorporating a filter which is easy to remove and replace.
The remote filter referenced above shall be factory mounted.

17. TANK(S) - FUEL:

One (1) 100 gallon minimum total capacity cylindrical aluminum or stainless steel, unpainted Safety-type fuel tank as per the requirements of FMVSS.
Tank mounting hardware and brackets shall be for "severe duty" applications. Heavy duty aluminum or stainless steel with minimum 2 inch wide straps and rubber gaskets.
Accessible fill pipe (located at either end of tank to avoid interference with steps).
System shall be a top draw and top return line.

18. TIRES/WHEELS:

Steel belted radials, all tires balanced with proper wheels for reference size, tubeless tires.
Decals stating the recommended tire pressure shall be attached on the road side one (1) above the front tire and one (1) above the rear axle the size shall be approximately 1.50 inch high and 3 inch long and read "PSI".
Tires shall be Goodyear or Michelin, all-season tread design pattern on drive axles.
The truck shall be equipped with hub piloted steel disc wheels for tubeless tires. The wheel end shall be equipped with outboard cast brake drums, and 15 degrees tubeless steel wheels, hub piloted, 10 hole - 285.75mm bolt circle with 22mm two-piece flange nuts.
Front: Wheels: 22.5 x 8.25, 10 hole - 285.75mm bolt circle with 220mm bore, tubeless steel disc wheel rated at 7,500 LB at a maximum inflation pressure of 120 PSI. Accuride part number 28828.

SPECIFICATIONS

A-56-FQ-C-AW / M-57-CT-F-AX / M-57-CT-Z-AV

I. GENERAL TRUCK SPECIFICATIONS (033100, 033200, 033300, 033500, 033700, 033900):
(Continued)

D. VEHICLE COMPONENTS: (Continued)

18. TIRES/WHEELS: (Continued)

Tires: 11R22.5

Rear: Wheels: 22.5 x 8.25, 10 hole - 285.75mm bolt circle with 220mm bore, tubeless steel disc wheel rated at 7,500 LB at a maximum inflation pressure of 120 PSI. Accuride part number 28828.

The dual rear wheel/tire assembly shall have clearance between the tires which permits the use of dual tire chains.

Wheel-Guard Separators: The wheel ends shall be equipped with the Accuride part number 5903 Wheel Guard Separator as follows:

Front axle - between the wheel and the brake drum.

Rear axle - between the inner dual and the brake drum and between the inner and outer duals.

Paint: The wheels shall be topcoat painted with TGIC Polyester Powder Paint MLD-82008 High Gloss Gray or equal applied over Cathodic Electro-Disposition Gray Primer.

19. FIFTH WHEEL:

36 inch diameter, sliding fifth wheel type, mounted to provide proper turning clearance when pulling a low-boy trailer. Location of fifth wheel setting to be determined by Manufacturer's Engineering Department in order to supply a unit that is totally engineered. There shall be aluminum diamond deck fenders that cover the entire tops of tandem and are full radius, removable, fenders. They shall be properly mounted in such a way as to support a 200 LB operator when walked upon while being easily removable (for servicing).

Fifth Wheel Mounting:

Mounting must be made to permit proper tire swing clearance and must maintain the maximum over all dimension keeping in mind all truck and trailer dimensions per all Federal and State regulations..
Mounting of fifth wheel to frame by angles.

There shall be spray suppressant [protection (REF: Schlegel Corp., Tel: (708) 437-8800) The entire length of the fenders.

20. WARNING LIGHT:

Per EQN -210B. Warning light shall be pedestal mounted, aft of the cab, on the roadside above cab level. Under no circumstances will the light be roof or cab mounted.

SPECIFICATIONS

A-56-FQ-C-AW / M-57-CT-F-AX / M-57-CT-Z-AV

I. GENERAL TRUCK SPECIFICATIONS (033100, 033200, 033300, 033500, 033700, 033900):
(Continued)

D. VEHICLE COMPONENTS: (Continued)

21. WINCH:

If stated in the "Invitation to Bid", unit shall include a worm gear winch fully outfitted and operational, rated at a minimum working load of 35,000 LB. It shall be oil-cooled, fully adjustable, with an automatic safety brake. Drum shall be polished and heat treated. Drum shall be mechanically or hydraulically driven. Reference model Braden Model AM(H)SW12-12F or equal. All safety and operator instructions shall be posted on an aluminum or stainless steel placard in close proximity to the winch. Unit shall be located behind the cab.

22. WET LINE (033200, 033500, 033900, 034300, 034700 only):

If stated in the "Invitation to Bid", units shall include a wet line system. All hoses, quick connections, hardware, fittings and hydraulic pump necessary to ensure a serviceable system shall be included. If unit bid is not mated with a new tractor, you may contact the Equipment Division at (717) 783-2371 to inspect the Department's tractor.

SPECIFICATIONS

A-56-FQ-C-AW / M-57-CT-F-AX / M-57-CT-Z-AV

II. GENERAL 35 TON TANDEM TRAILER SPECIFICATIONS (033300, 033500, 034100, 034300):

A. INTENT STATEMENT:

The purpose of these specifications is to describe a dropdeck, lowbed semi-trailer with hydraulic detachable gooseneck and non-ground engaging to be used in hauling construction machinery without a tractor. The trailer will be rated for a capacity load of 35 U.S. tons in 1/2 of the deck length at highway speeds of 65 MPH. The trailer to be described will be a tandem axle. It shall be equipped with a hydraulic detachable gooseneck so equipment can be loaded over the front of the deck. Tapered main beams shall be provided to permit the entire taper to be lowered as flush to the ground as possible. The mainframe beam hooks and other components on the trailer portion must be flush to the slope front in order to facilitate the loading of rollers, and "all" Department equipment with a limited and reasonable amount of blocking/center ramping.

All vendors should review our fleet with the manufacturer's engineering department and our field personnel prior to bidding to ensure that the trailer manufacturer is aware of the tasks assigned to this unit.

The trailer must be compatible with the Department tandem axle tractor(s) in critical areas as hoses, electrical connectors, fifth wheel clearance and pin size.

NOTE: EQN-253 is offered as reference except for ground to top of deck height which shall not exceed 23 inches to 25 inches and flat deck useable length which shall be 276 inch (+ or - 6 inch).

Special Note:

It shall be the sole responsibility of the successful vendor to ensure compatibility with the Department's tractor(s), to include not surpassing the overall length ruling and meeting all bridge formulas. This is of particular note to those orders received for trailers without tractors. The vendor shall, prior to bid, inspect the Department's tractor/s to ensure this compatibility. For tractor location contact the Equipment Division at 717-783-2371.

Department of General Service PCID NO. 1075 is included as part of this specification. PCID NO. 1075 may be reviewed and downloaded from the Department of General Services website, www.dgs.state.pa.us.

Delivery as required per Department of General Service PCID NO. 1075 section G. All units must be delivered within 120 days after receipt of the purchase order by the successful bidder.

SPECIFICATIONS

A-56-FQ-C-AW / M-57-CT-F-AX / M-57-CT-Z-AV

II. GENERAL 35 TON TANDEM TRAILER SPECIFICATIONS (033300, 033500, 034100, 034300):
(Continued)

B. TRAILER COMPONENTS:

1. AXLE AND SUSPENSION:

The trailer shall be equipped with the following axle and suspension:

AXLE: Two (2) 25,000 LB capacity axles.
SUSPENSION: Air Ride Suspension. Ref: Turner HT25OU, Neway, Ridewell, or approved equal.

2. BRACKETS: - SIDE:

The main deck shall be equipped with a set of twenty (20) minimum heavy duty side brackets. The side brackets will be cast from ductile iron, D5506, Tensile 80K, Yield 55K specification A-536-72, Grade 80-55-06. There will be required ten (10) each side minimum, to increase the width to 10 feet if desired.

When not in use, they shall be held in place against the side member with spring loaded clips. A full 2 inch x 10 inch (minimum) No. 1 grade oak planks shall be furnished to provide covering full length of the brackets on each side.

3. BRAKES:

The service brake shall be a two-line system with an emergency breakaway feature conforming to ICC and Commonwealth of Pennsylvania Specifications. The complete system shall include necessary tubing, glad hands connectors at the front of the gooseneck, reservoir(s), (minimum 1500 cubic inch capacity), remote drain cock and type 30 air chamber with self adjusting slack adjusters of the clearance sensing type for each brake drum. Air chamber shall be mounted parallel to or below the axles. The brake shoes shall be the two (2) shoe internal expanding type with molded block lining 16.5 inch x 7 inch 4S, 2M ABS anti-lock system.. There shall be a spring parking brakes installed on two (2) trailer axles.

4. DIMENSIONS:

King pin setting will be minimum 15 inch, maximum 16 inch.

Overall width 8 feet.

Deck length less ramp, actual usable flat deck 23 feet (+ or - 6 inch).

Roadway clearance, not less than 9 inch, light dimension

Height from ground to underside of gooseneck fifth wheel plate at kingpin, loaded on level and parallel surface approximately 49 inch to 52 inch.

SPECIFICATIONS

A-56-FQ-C-AW / M-57-CT-F-AX / M-57-CT-Z-AV

II. GENERAL 35 TON TANDEM TRAILER SPECIFICATIONS (033300, 033500, 034100, 034300):
(Continued)

B. TRAILER COMPONENTS: (Continued)

5. ELECTRIC SYSTEM:

The battery shall be a minimum of 540 CCA @ 0 degrees F (sealed) with stud type connector with all copper cables.

Shock-mounted battery installation, 0.25 inch rubber.

The trailer shall be furnished with shock proof running lights, directional signals and reflectors, fully complying with ICC minimum requirements, and with the Motor Vehicle Laws and Regulations of the Commonwealth of Pennsylvania. All lights shall be recessed or otherwise provided with adequate guards to prevent accidental damage. All lights shall be LED.

All wiring shall be per EQN-75 (no substitute).

6. ENGINE AND ENGINE COMPARTMENT:

11 hp engine minimum, with exterior waterproof controls, Ref. Models Kohler, Briggs & Stratton, Robin/Subaru or Honda. Electric start.

Exhaust system with muffler routed to exterior of compartment and clear of the operator and framing. Exhaust leaks will not be acceptable.

Engine oil dipstick. Engine shall be removable by disconnecting 4 bolts for ease of shop maintenance. Minimum 5 GPM pump (hydraulic).

FAST LUBE OIL CHANGE SYSTEM (FLOCS)

This system will be installed with all fittings, brackets, clamps and hoses. The system will be compatible with all fittings presently used by the Department. The final placement of the male half of the snap coupler on the equipment will be determined at the pre-build meeting.

RE: AEROQUIP or prior approved equal. Ref: EQN-351A.

7. FRAME:

All longitudinal carrying members shall be high strength low alloy steel. The main-beams shall consist of two (2) 16 inch deep I-Beams. These beams shall have a minimum flange thickness of .625" and a maximum width of 8 inch. The material utilized in the flanges shall be ASTM GR-A514. The flanges shall be welded to a web that shall have a minimum thickness of .3125 inch and a maximum width of 14.75 inch. Material used for the web of these main-beams shall be ASTM A572. These main-beams when completely fabricated shall have a weight of 50# per foot. All welding in the construction of these main-beams will be accomplished by use of a submerged arc with preheating and automatic feed. The main-beams shall be tapered for approximately nine (9) feet running from front to back. The front profile of the deck shall be tapered, and shall not exceed eight (8) inches in height when detached from the gooseneck and in the loading position. The trailer's heavy duty side channels shall be C12 x 20.7# low alloy steel with minimum yield strength of 50K, ASTM A572GR 50 with a section modulus of 21.5. There shall be a minimum of ten (10) cross-members in the trailer deck, pierced through the main-beams. The first and last cross-members shall be MC10 x 20# ASTM A572 GR 50. All other cross-members shall be W10 x 12#.

SPECIFICATIONS

A-56-FQ-C-AW / M-57-CT-F-AX / M-57-CT-Z-AV

II. GENERAL 35 TON TANDEM TRAILER SPECIFICATIONS (033300, 033500, 034100, 034300):
(Continued)

B. TRAILER COMPONENTS: (Continued)

7. FRAME: (Continued)

The beam hooks attached to the main-beams must be designed to follow the sloping contours of the longitudinal main-beams to allow a roller to be loaded without going over a "hump". The beam hooks shall be a minimum of six (6) inches thick, flame cut from ASTM A572 GR42 plate stock. Welding of multiple plates together to equal six (6) inches shall not be acceptable.

8. GOOSENECK:

The gooseneck shall be a flat, hydraulic detachable type with a scraper-neck profile for additional load maneuverability. It shall be equipped with a non-ground engaging feature.

The gooseneck to deck connection must be accomplished through a mating set of, minimum, 6 inch hooks. The gooseneck connection/disconnection shall be accomplished by the operation of a lever and spring pin which effectively stows two (2) 1.25 inch x 5.50 inch x 11.25 inch steel bars and two (2) safety pins into the gooseneck cavity. The safety pins provided are to be of an automated nature and attachment to the gooseneck in such a manner as to eliminate the need for the operator to reach underneath the structure of the gooseneck to secure them. "Tear drop" type pins are acceptable in lieu of hooks.

The main gooseneck beams (running parallel to the ground) shall be high strength low alloy steel. These beams shall have a minimum flange thickness of .50 inch and a maximum width of six (6) inches. The material used in the flanges shall be ASTM GR A514. The flanges shall be welded to a web that shall have a minimum thickness of .3125 inch and a maximum width of sixteen (16) inches. Material used for the web of the beams shall be ASTM A572. All welding in the construction of these main-beams will be accomplished by use of a submerged arc with preheating and automatic feed. The gooseneck main beams will be tapered the final 33.5 inch (deck end) to form the scraper-neck profile. The remaining length of the gooseneck main beam may be tapered in another fashion to provide maximum strength.

The design of the hydraulic detachable gooseneck shall be adjustable, up or down, to clear road obstacles, under full load, without shifting the load. The hydraulic system for operating this gooseneck shall be complete, consisting of necessary operating valves, relief valve, reservoir and pump, driven by a self contained engine. The operating pressure of the hydraulic system shall not exceed 2,800 PSI. A tool box shall be mounted in/on the gooseneck.

The length of the gooseneck must be calculated based on the fifth wheel being placed 6 inch, to the front of the tractor axle using frame dimensions supplied by the truck manufacturer.

The engine, battery, hydraulic filter and other items housed in the gooseneck shall be covered by a full hood to protect these items. The hood shall be hinged for easy access and have a fastener to keep it in the open position. The design shall provide easy access for general maintenance. The hood shall have a handle for lifting, and a lock with keys. This paragraph is not applicable if unit/s to be supplied are to have wet line.

NOTE: All items utilized shall be installed in accordance with SAE standards and practices. If hood must be lifted for engine cooling when in operation there must be a visible, weather-proof decal stating so.

SPECIFICATIONS

A-56-FQ-C-AW / M-57-CT-F-AX / M-57-CT-Z-AV

II. GENERAL 35 TON TANDEM TRAILER SPECIFICATIONS (033300, 033500, 034100, 034300):
(Continued)

B. TRAILER COMPONENTS: (Continued)

9. LASHING RINGS:

Twelve (12) lashing rings shall be provided, five (5) on each side of platform and two (2) on rear. They shall be constructed of 1 inch diameter C1030 steel.

10. PLATFORM SIZE AND CONSTRUCTION:

The platform shall have a minimum 1 ¾" oak or a minimum 1 ¼" Apitong full floor. The trailer decking shall be composed of #1 grade hardwood to carry the rated capacity within any 11 foot section, of the deck, and shall be supported by maximum 24 inch centered cross members (see "Frame") or laminated "Transdeck" (AINSWORTH LUMBER CO. LTD). (NOTE: A nominal 2 inch floor is not acceptable.) There shall be flooring across the entire width and length of trailer. Two (2) fold down steel framed front ramps with oak inserts shall be provided to form a sloping approach to the deck area. The ramp shall be tapered to afford a 14 degree loading angle. The ramp shall be designed to provide an easy transition from the road surface to the ramp and have a maximum ramp-to-trailer gap of 3 inches (e.g. - loading of a steel wheel roller). All cross members shall be welded to the main frame members. Side channel flange reinforcements are required. The cross members shall be pierced through the main frame longitudinals. Spacing on the cross members shall be on 30 inch centers. Deck attachment shall be secured through the use of countersunk button head carriage bolts and floor clips. There shall be no drilling into cross members for any reason.

Platform to ground height shall not exceed that shown in EQN-253.

11. ACCESS:

Front loading ramps shall have oak inserts to form a maximum angle of 14 degrees slope. The rear riser between the main deck and the rear frame shall not exceed 30 degrees.

12. RUSTPROOFING/PAINT:

The entire undercarriage shall be coated with black, rustproof undercoating.

Paint: PennDOT yellow, ref. DuPont 6808 shade only (entire unit, less wood).

Tractor color shall match trailer color (if sold as a set). All metal surfaces shall have rust preventive treatment or primer.

All metal surfaces including rims shall be cleaned prior to primer and final painting.

The sides of the trailer and rear shall be per EQN-127A.

SPECIFICATIONS

A-56-FQ-C-AW / M-57-CT-F-AX / M-57-CT-Z-AV

II. GENERAL 35 TON TANDEM TRAILER SPECIFICATIONS (033300, 033500, 034100, 034300):
(Continued)

B. TRAILER COMPONENTS: (Continued)

13. REAR FRAME:

The rear frame shall be constructed of fabricated beams, channels and plate. The longitudinal members shall be high strength, low alloy steel. These members shall have a minimum flange thickness of .375 inch and a minimum width of seven (7) inches. The material utilized in the flanges shall be ASTM-A514. The flanges shall be welded to a web that shall have a minimum thickness of .3125 inch and a maximum width of sixteen (16) inches. Material used for the web of these longitudinal members shall be ASTM-A572. All welding in the construction of these main-beams will be accomplished by use of a submerged arc with preheating and automatic feed. Also included in the rear frame is a load bearing formed trunnion outrigger(s) between the tires. The rear frame tires shall be shielded to permit equipment to be set on this area of the trailer. These covers shall permit proper tire clearance and shall be a load-bearing formed frame between the tires of the first and last axles covered with .500 inch smooth steel plate, and 1 inch angle iron, inverted and placed left to right and welded in place at 6 inch intervals for the entire length.

Rear mud flaps in accordance with PA State Inspection Laws.

14. TIRES, WHEELS, RIMS, AXLES:

The trailer shall be provided with steel belted radial tires 255/70R 22.5 (H) 16 ply rating mounted on 22.5 x 8.25 rims, hub piloted steel disc, Accuride (no substitute) The tires shall not extend above the bridge beams. Lug wrench shall be provided and stowed with holder on the gooseneck. Spare rim and tire mounted and stowed on the gooseneck, one (1) per trailer with locking tire carrier. The axles shall have a 71 inch track length. Each shall be a through-type design with a 5 inch round outer dimension. They shall be of cast ductile iron, hub piloted design with integral hubs. They shall have detachable drums and shall be equipped with an oil seal assembly. (REF: Webb or equal.

15. MISCELLANEOUS:

There shall be a flag holder welded to each side of the rear frame rail.

There shall be a two piece hinged "OVERSIZED LOAD" sign mounted on the rear. The sign shall be mounted in such a way to afford removal without the use of tools.

There shall be two red flags with each unit.

There shall be a "flasher kit" for rear trailer lights. It shall include a wet cell battery and a recharging feature and capable of being connected to a tractors charging system.

16. NOTES:

A decal stating the light weight of the trailer shall be attached on the road side near the lift controls. The decal shall be approximately 1.50 inches high and 3 inches long and read L.W. _____LB.

SPECIFICATIONS

A-56-FQ-C-AW / M-57-CT-F-AX / M-57-CT-Z-AV

II. GENERAL 35 TON TANDEM TRAILER SPECIFICATIONS (033300, 033500, 034100, 034300):
(Continued)

B. TRAILER COMPONENTS: (Continued)

16. NOTES: (Continued)

A decal stating "(MLWR)" trailers actual load carrying capacity is _____, shall be attached in a clearly visible area of the trailer.

A decal stating the recommended tire pressure shall be attached on the roadside above the rear axle, the size shall be approximately 1.50 inches high and 3 inches long and read " ___PSI". Decal shall read the same rating as the tire.

17. WET LINE (033500, 034300):

If stated in the "Invitation to Bid", unit(s) shall include a wet line system (section II.B.6. shall be voided). All hoses, quick connections, hardware and fittings necessary to ensure a serviceable system shall be included. If unit bid is not mated with a new tractor, you may contact the Equipment Division at (717) 783-2371 to inspect the Department's tractor.

SPECIFICATIONS

A-56-FQ-C-AW / M-57-CT-F-AX / M-57-CT-Z-AV

III. GENERAL 50 TON TRI-AXLE TRAILER SPECIFICATIONS (033700,033900, 034500, 034700):

A. INTENT STATEMENT:

The purpose of these specifications is to describe a 50-ton, three-axle, drop-deck, low-bed semi-trailer to be used in hauling construction machinery, without a tractor. The trailer will be rated for a capacity load of 50 U.S. tons in 1/2 of the deck length at highway speeds of 65 MPH. It shall be equipped with a self lifting (non ground bearing) hydraulic detachable gooseneck so equipment can be loaded over the front of the deck. Tapered main beams shall be provided to permit the entire taper to be lowered as flush to the ground as possible. The gooseneck beam hooks and other components on the trailer portion must be flush to the slope front in order to facilitate the loading of rollers, and "all" Department equipment with a limited and reasonable amount of blocking/center ramping. The trailer must be new, including all component parts.

All vendors should review our fleet with the manufacturer's engineering department and our field personnel prior to bidding to ensure that the trailer manufacturer is aware of the tasks assigned to this unit.

The trailer must be compatible with the Department's tandem axle tractor(s) in critical areas as hoses, electrical connectors, fifth wheel clearance and pin size.

NOTE: EQN-253 is offered as reference except for ground to top of deck height which shall not exceed 23 inches to 25 inches and flat deck useable length which shall be 276 inches (+ or - 6 inches).

Special Note:

It shall be the sole responsibility of the successful vendor to ensure compatibility with the Department's tractor(s), to include not surpassing the overall length ruling and meeting all bridge formulas. This is of particular note to those orders received for trailers without tractors. The vendor shall, prior to bid, inspect the Department's tractor/s to ensure this compatibility. For tractor location contact the Equipment Division at 717-783-2371.

Department of General Service PCID NO. 1075 is included as part of this specification. PCID NO. 1075 may be reviewed and downloaded from the Department of General Services website, www.dgs.state.pa.us.

Delivery as required per Department of General Service PCID NO. 1075 section G. All units must be delivered within **120** days after receipt of the purchase order by the successful bidder.

SPECIFICATIONS

A-56-FQ-C-AW / M-57-CT-F-AX / M-57-CT-Z-AV

III. GENERAL 50 TON TRI-AXLE TRAILER SPECIFICATIONS (033700,033900, 034500, 034700):
(Continued)

B. TRAILER COMPONENTS:

1. AXLE AND SUSPENSION:

The trailer shall be equipped with the following axle and suspension:

AXLE: Three (3) axles, each axle shall be rated at 25,000 lbs. capacity by the axle manufacturer. The wheel bearings shall be an oil-bathed type. Each shall be a through-type design with a 5 inch round outer dimension. They shall be of cast ductile iron

SUSPENSION: Each of the three axles shall be equipped with an air ride suspension rated at 25,000 lbs. capacity by the suspension manufacturer. The suspension shall require no lubrication.

The suspension shall also include a height control system to mechanically adjust the ride height of the suspension by (3) three inches up or down. This system shall have (5) positions – (2) positions to increase the standard ride height, (1) standard ride height, and (2) positions to decrease the standard ride height.

2. BRACKETS: - SIDE:

The main deck shall be equipped with a minimum set of twenty (20) heavy duty side brackets. The side brackets will be cast from ductile iron, D5506, Tensile 80K, Yield 55K specification A-536-72, Grade 80-55-06. There will be required ten (10) each side minimum, to increase the width to a minimum of 10 feet if desired.

When not in use, they shall be held in place against the side member with spring loaded clips. A full 2 inch x 10 inch (minimum) No. 1 grade oak planks shall be furnished to provide covering full length of the brackets on each side.

Fabricated side brackets shall be deemed unacceptable.

3. BRAKES:

The service brake shall be a two-line system with an emergency breakaway feature conforming to ICC and Commonwealth of Pennsylvania Specifications. The complete system shall include necessary tubing, glad hands connectors at the front of the gooseneck, reservoir(s), (minimum 1500 cubic inch capacity), a relay emergency valve, drain cock and type 30 air chamber with self adjusting slack adjusters of the clearance sensing type for each brake drum. Air chamber shall be mounted parallel to or below the axles. The brake shoes shall be the internal expanding type with molded block lining 16.5 inch x 7 inch. There shall be a spring parking brake installed on (1) one trailer axle.

All precautions shall be taken to prevent the brake mechanism from being damaged by road hazards.

SPECIFICATIONS

A-56-FQ-C-AW / M-57-CT-F-AX / M-57-CT-Z-AV

III. GENERAL 50 TON TRI-AXLE TRAILER SPECIFICATIONS (033700,033900, 034500, 034700):
(Continued)

B. TRAILER COMPONENTS: (Continued)

4. DIMENSIONS:

King pin setting will be minimum 15 inches, maximum 16 inches.

Overall width 8 feet.

Deck length less ramp, actual usable flat deck 23 feet (+ or - 6 inches).

Roadway clearance, not less than 9 inches, light dimension

Height from ground to underside of gooseneck fifth wheel plate at kingpin, loaded on level and parallel surface approximately 49 inches to 52 inches.

5. ELECTRIC SYSTEM:

The battery shall be a minimum of 540 CCA @ 0 degrees F (sealed) with stud type connector with all copper cables.

Shock-mounted battery installation, 0.25 inch rubber.

The trailer shall be furnished with a complete 12-volt lighting system, shock proof running lights, directional signals and reflectors, fully complying with ICC minimum requirements, and with the Motor Vehicle Laws and Regulations of the Commonwealth of Pennsylvania. All lights shall be recessed or otherwise provided with adequate guards to prevent accidental damage. All lights shall be LED.

The 12 volt wiring system shall be contained in modular-type, water-resistant harnesses.

All wiring that runs through cross members shall be adequately protected from grounding.

All wiring shall be per EQN – 75.

6. ENGINE AND ENGINE COMPARTMENT:

11 hp engine minimum, with exterior waterproof controls, Ref. Models Kohler, Briggs & Stratton, Robin/Subaru or Honda.

Electric start.

Exhaust system with muffler routed to exterior of compartment and clear of the operator and framing. Exhaust leaks will not be acceptable.

Engine oil dipstick, drain hole and drain plug extension as required to enable proper oil changes. The engine, hydraulic filter and other items housed in the gooseneck shall be covered, the hood shall have a handle for lifting, and a lock with keys. This paragraph is not applicable if unit(s) to be supplied are to have wet line(s).

Engine shall be removable by disconnecting 4 bolts for ease of shop maintenance.

Minimum 5 GPM pump (hydraulic).

Fast Lube Oil Change System (FLOCS)

This system will be installed with all fittings, brackets, clamps and hoses. The system will be compatible with all fittings presently used by the Department. The final placement of the male half of the snap coupler on the equipment will be determined at the pre-build meeting.

RE: AEROQUIP or prior approved equal. Ref: EQN-351A.

SPECIFICATIONS

A-56-FQ-C-AW / M-57-CT-F-AX / M-57-CT-Z-AV

III. GENERAL 50 TON TRI-AXLE TRAILER SPECIFICATIONS (033700,033900, 034500, 034700):
(Continued)

B. TRAILER COMPONENTS: (Continued)

7. FRAME:

The frame shall be constructed of two (2) heavy-duty beams and two (2), heavy duty channels. The main beams shall be W16 x 67# low alloy steel rated a minimum of 60,000 PSI ASTM-A 572 GR60 with a section modulus of 117. The main beams shall be tapered for approximately 9 feet, running front to back. The front profile of the deck shall be tapered and no higher than 8 inches when detached from the gooseneck and in the loading position. The trailer's heavy duty side channels shall be C12 x 20.7# low alloy steel rated a minimum of 50,000 PSI, ASTM-A 572 GR50 with a section modulus of 21.5. There shall be ten (10) total cross members in the trailer deck, pierced through the main beams. The first and last cross members shall be MC10 X 25#. The intermediate cross beams shall be W10 x 12#.

The beam hooks must be designed to follow the sloping contours of the longitudinal main beams to allow a roller to be loaded without going over a "hump". The beam hooks shall be minimum 6 inches thick, made from ASTM-A572 GR 42 plate stock. Welding of two or more plates together to equal 6 inches shall not be acceptable.

8. GOOSENECK:

The longitudinal carrying members shall be fabricated, using high-strength, low-alloy steels. The web shall be fabricated using ASTM A572-GR50 50,000 psi minimum yield steel; and the flanges shall be fabricated using ASTM A514, 100,000 psi minimum yield steel.

The gooseneck shall be a tapered, self-lifting, detachable type with a "Scraper-neck" profile for additional load clearance.

It shall be equipped with two (2) 8 inch x 14 inch double acting hydraulic cylinders with 3 inch rods, anchored in a horizontal position in the gooseneck. These cylinders shall push off a lever which, in turn, pushes off the deck of the trailer. The cylinders shall require a maximum of 2,800 psi to operate the gooseneck. The lifting mechanism shall not carry the load in the normal transport of the trailer.

The gooseneck must also be equipped with a 2 inch kingpin (conforming to SAEJ700a) properly boxed to prevent cracking and dishing of the fifth wheel plate. The upper fifth wheel plate shall be adequate in size for coupling to a 36 inch fifth wheel or a full oscillation fifth wheel.

The design of the hydraulic detachable gooseneck shall be adjustable, up or down, to clear road obstacles, under full load, without shifting the load. The hydraulic system for operating this gooseneck shall be complete, consisting of necessary operating valves, relief valve, reservoir and pump, driven by a self contained engine (unless using a wet-line). A tool box shall be mounted in/on the gooseneck. "Tear drop" type pins are acceptable in lieu of hooks.

The length of the gooseneck must be calculated based on the fifth wheel being placed 6 inch, to the front of the tractor axle using frame dimensions supplied by the truck manufacturer.

NOTE: All items utilized shall be installed in accordance with SAE standards and practices. If hood must be lifted for engine cooling when in operation there must be a visible, weather-proof decal stating so.

SPECIFICATIONS

A-56-FQ-C-AW / M-57-CT-F-AX / M-57-CT-Z-AV

III. GENERAL 50 TON TRI-AXLE TRAILER SPECIFICATIONS (033700,033900, 034500, 034700):
(Continued)

B. TRAILER COMPONENTS: (Continued)

9. LASHING RINGS:

Sixteen (16) drop forged lashing D's of 1 inch diameter steel (C1030 steel construction) shall be provided.

They shall be positioned as follows: six on each side of the deck, one on end of each trunnion beam. Bidders shall include test results from an independent testing agency detailing strength and characteristics of the lashing D's to be supplied. Testing shall be done in accordance with the Trailer Cargo Anchoring Devices Test Method 906, Transport Canada.

10. PLATFORM SIZE AND CONSTRUCTION:

The platform shall have a minimum 1 ¾" oak or a minimum 1 ¼" Apitong full floor. The trailer decking shall be composed of #1 grade hardwood to carry the rated capacity within any 11 foot section, of the deck, and shall be supported by maximum 24 inch centered cross members laid longitudinally with the planking secured to the cross members with countersunk button head carriage bolts and floor clips. The hardwood decking shall be fitted to eliminate gaps.

There shall be flooring across the entire width and length of trailer. There shall be no drilling into cross members for any reason.

Platform to ground height shall not exceed that shown in EQN-253.

11. ACCESS:

Two (2) 24 inch long by 22 inch wide front fold-down loading ramps with oak inserts shall be provided to form a 13-degree approach to the main deck area. These sliding ramps shall be adjustable from 114 inches out-to-out to 32 inches in-to-in.

The front of the main beams and side beams shall be tapered on the top to permit easy loading. Also the bottom of the main beams and side beams must facilitate the deck resting evenly on the ground for safe loading.

12. RUSTPROOFING/PAINT:

Prior to welding and assembly the steel shall be shot-blasted and buffed. Prior to painting the steel shall be cleaned and ground to eliminate splatter and scale.

The entire underside of the frame shall be coated with black, rustproof undercoating.

Preparation and Primer

The assembled frame shall be primed with moisture cure urethane primer.

Paint: PENNDOT yellow, ref. Dupont 6808 for color only (entire unit, less wood). The frame shall be finished with one coat of the manufacturer's lead-free and chromate-free rust preventative coating.

Tractor color shall match trailer color (if sold as a set). All metal surfaces shall have rust preventive treatment or primer.

All metal surfaces including rims shall be cleaned prior to primer and final painting.

The sides of the trailer and rear shall be per EQN-127A.

SPECIFICATIONS

A-56-FQ-C-AW / M-57-CT-F-AX / M-57-CT-Z-AV

III. GENERAL 50 TON TRI-AXLE TRAILER SPECIFICATIONS (033700,033900, 034500, 034700):
(Continued)

B. TRAILER COMPONENTS: (Continued)

13. REAR FRAME:

The main carrying members of the rear frame shall be fabricated using high-strength, low alloy steel. The flanges shall be fabricated from 130,000 psi material. The web shall be fabricated from ASTM A572 GR50 material.

Access to Rear Frame

The rear riser section shall run at a 33° angle between the main deck and the rear frame area and have an 18 inch drop between these two parts of the trailer.

The rear frame shall include wide trunnion beams between each set of wheels. The trunnions shall be capable of supporting appropriate equipment.

Also included in the rear frame is a load bearing formed trunnion outrigger(s) between the tires. The rear frame tires shall be shielded to permit equipment to be set on this area of the trailer. These covers shall permit proper tire clearance and shall be a load-bearing formed frame between the tires of the first and last axles covered with .500 inch smooth steel plate, and 1 inch angle iron, inverted and placed left to right and welded in place at 6 inch intervals for the entire length.

Rear mud flaps in accordance with PA State Inspection Laws.

14. TIRES, WHEELS, RIMS:

The trailer shall be provided with steel belted radial tubeless tires 255/70R 22.5 (H) 16 ply rating mounted on 22.5 x 8.25 hub piloted steel disc rims, Accuride no substitute.

The hubs shall be ten (10) stud, hub-piloted type and made of cast ductile iron.

The tires shall not extend above the bridge beams. Lug wrench shall be provided and stowed with holder on the gooseneck. Spare rim and tire, mounted and stowed on the gooseneck. One (1) per trailer with locking tire carrier.

15. MISCELLANEOUS:

There shall be a flag holder welded to each side of the rear frame rail.

There shall be a two piece hinged "OVERSIZED LOAD" sign mounted on the rear. The sign shall be mounted in such a way to afford removal without the use of tools.

There shall be two red flags with each unit.

There shall be a "flasher kit" for rear trailer lights. It shall include a wet cell battery and a recharging feature capable of being connected to a tractors charging system.

SPECIFICATIONS

A-56-FQ-C-AW / M-57-CT-F-AX / M-57-CT-Z-AV

III. GENERAL 50 TON TRI-AXLE TRAILER SPECIFICATIONS (033700,033900, 034500, 034700):
(Continued)

B. TRAILER COMPONENTS: (Continued)

16. NOTES:

A decal stating the light weight of the trailer shall be attached on the road side near the lift controls. The decal shall be approximately 1.50 inches high and 3 inches long and read L.W. ____LB.

A decal stating "(MLWR)" trailers actual load carrying capacity is , _____ shall be attached in a clearly visible area of the trailer.

A decal stating the recommended tire pressure shall be attached on the roadside above the rear axle, the size shall be approximately 1.50 inches high and 3 inches long and read "____ PSI".
Decal shall read the same rating as the tire.

17. WET LINE (033900, 034700):

If stated in the "Invitation to Bid", unit(s) shall include a wet line system (section III. B.6. shall be voided). All hoses, quick connections, hardware and fittings necessary to ensure a serviceable system shall be included. If unit bid is not mated with a new tractor, you may contact the Equipment Division at (717) 783-2371 to inspect the Department's tractor.

SPECIFICATIONS

A-56-FQ-C-AW / M-57-CT-F-AX / M-57-CT-Z-AV

IV. DRAWINGS:

EQN-75	dated	Rev.	10-30-06	1 sheet	TRAILER LIGHTING/ELECTRIC
EQN-78	dated	Rev.	10-27-06	1 sheet	CB RADIO CONNECTIONS
EQN-81A	dated	Rev.	02-27-07	1 sheet	7 WAY TRAILER CONNECTOR
EQN-127A	dated	Rev.	11-03-06	1 sheet	CONSPICUITY TAPE STRIPING REQUIREMENTS
EQN-131	dated	Rev.	01-19-06	1 sheet	TRACTOR CONSPICUITY
EQN-160	dated	Rev.	01-02-07	1 sheet	CENTRALIZED LUBE SYSTEM
EQN-210B	dated	Rev.	05-29-07	sheets 1 & 2 of 3	REVOLVING WARNING LIGHTS
EQN-252	dated	Rev.	05-21-02	1 sheet	LOWBOY TRAILER FIXED THREE AXLE
EQN-253	dated	Rev.	02-12-07	1 sheet	LOWBOY TRAILER TANDEM
EQN-351A	dated	Rev.	10-20-06	2 sheets	FAST LUBE OIL CHANGE SYSTEM (FLOCS)

The above referenced drawings shall become part of these specifications. These drawings reflect the intent of the Department and any discrepancies shall be resolved at the pre-build meeting.

NOTE: DRAWINGS APPEAR AT THE END OF THE SPECIFICATION.

SPECIFICATIONS

A-56-FQ-C-AW / M-57-CT-F-AX / M-57-CT-Z-AV

V. MANUALS:

The successful vendor shall furnish all applicable manuals per unit:

- 1 Operator's
- 1 Parts
- 1 Service
- 1 Engine
- 1 Transmission (Automatic or Manual)
- 1 Body and Sub-frame (Parts and Service)
- 1 Complete set of manuals for any additional items/equipment added to a piece of equipment.

The manuals listed shall be official O.E.M. publications supplemented with technical manuals for all components as published by sub-vendors/manufacturers.

Parts Manual presented must be a relative to "all" items utilized to build these units, with appropriate part numbers.

Delivery of these manuals shall be completed within a maximum of 90 days after the pilot model is accepted.

Manuals may be supplied on CD Disc in lieu of paper manuals.

SPECIFICATIONS

A-56-FQ-C-AW / M-57-CT-F-AX / M-57-CT-Z-AV

VI. TRAINING:

Mechanic:

The successful vendor shall provide services of qualified factory trained technicians for not more than ___0___ training session(s) of not more than ___0___ hours at ___0___ PENNDOT location(s) to train personnel for in-depth preventive maintenance, overhaul and review of the proper usage of parts and service manuals, as well as component/system adjustments that need to be monitored at specified service intervals.

Operator:

The successful vendor shall provide services of qualified factory trained technicians for not more than ___0___ training session(s) of not more than ___0___ hours at ___0___ PENNDOT location(s) to train personnel in the proper operation, safety and servicing of the equipment.

The successful vendor shall submit a training plan to the Equipment Division for approval within 45 days after receipt of the Purchase Order. The training plan shall consist of course outline and class schedule. Training must be completed within 60 days after the dates established in the approved training plan.

All training shall be coordinated with the District Equipment Managers, with the exception of Asphalt related training, which must be coordinated with the Statewide Training Coordinator (717) 787-4836, Fax (717) 783-4438.

VII. WARRANTY:

Per PCID No. 1075

Tractor per section E.1. plus the additional specific warranty items.

Trailer per section E. 3 plus the additional specific warranty items.

PARTNO.	OMEN NO:	QTY:	DESCRIPTION:
87250	01-8725-02	2	UBS 7-PIN RECEPTACLE 2 HOLE MOUNT
87031	01-8703-12	1	ULTRALINK 500 10/12 15" STRAIGHT/S/SBLUE
66310	01-6631-02	1	UBS MAIN HARNESS 60' 7W 8/10/12 W/44" DROP UBS
66001	01-6600-12	1	UBS REAR SILL HARNESS W/ BLUE DROP
66170	01-6617-02	2	UBS JUMPER STD/M/SSLF 24" OR 2"
01-3651-74	01-3651-74	1	ID/LICENSE LAMP JUMPER HARNESS
66161	01-6616-12	1	UBS JUMPER SLM/DSL F 55" OR 4' 7" BACK UP ALARM
67260	01-6726-02	4	UBS JUMPER SINGLE 7-PIN ADAPTER
67250	01-6725-02	3	UBS JUMPER DOUBLE 7-PIN ADAPTER
99510	01-9951-02	1	7-PIN RECEPTACLE TERMINAL KIT
67301	01-6730-12	1	UBS JUMPER 3'2" OR 38" DSLF CTF ROADSIDE FRONT MARKER
67303	01-6730-32	1	UBS JUMPER 14 ' OR 168" DSLF CTF CURBSIDE FRONT MARKER
67305	01-6730-52	2	UBS JUMPER 34' 6" OR 415" DSLF CENTER MARKERS
05-2002-11	05-2002-11	1	UBS JUMPER 3 WIRE ROADSIDE W/BL/Y 340"
05-2002-12	05-2002-12	1	UBS JUMPER 3 WIRE ROADSIDE W/BL/G 340"
01-7313-70	01-7313-70	1	BACKUP ALARM FOR 4" GROMMET MOUNT W/SLM/RT.DOT
52772	01-5277-22	4	TMI STT LAMP SEALED 4" RED
91740	01-9174-02	5	GROMMET 4" LAMP
45832	01-4583-22	5	MARKER LAMP 2 1/2" SEALED REFLEX RED
45833	01-4583-32	4	MARKER LAMP 2 1/2" SEALED REFLEX YELLOW
91410	01-9141-02	9	GROMMET 3" HOLE /4581/4582/4583/4701
60280	01-6028-02	1	LICENSE LAMP SEALED KIT ONE BULB US15 CL
66850	01-6685-02	6	UBS PIGTAIL D/SEAL SLM/SLM 4581/4582/4583/4701
52513	01-5251-32	2	MID-TURN / US60 / MARKER LAMP YELLOW
92420	01-9242-02	2	OVAL LAMP GROMMET
44690	01-4469-02	1	FLASHER 16 LAMP 2 LAMP PIN
99500-3	01-9950-03	10	BULLET TERMINAL CRIMP-ON 14 GA. UBS CUT TO FIT (150 PER BOX)
99501-3	01-9950-13	7	BULLET TERMINAL CRIMP-ON 12 GA. UBS CUT TO FIT (150 PER BOX)
99502-3	01-9950-23	11	UBS DUMMY PLUG SLMLINE (150PER BOX)

PA DEPARTMENT OF TRANSPORTATION

REVISIONS			LOWBOY TRAILER LIGHTING/ELECTRICAL		
NO	DATE	BY	DRAWN BY	SCALE	CHECK BY
1	02-19-97	WHM	WHM	N/A	EQN-75
2	08-06-98	DJA			
3	10-30-06	CJW			RED SHEET 1 OF 1

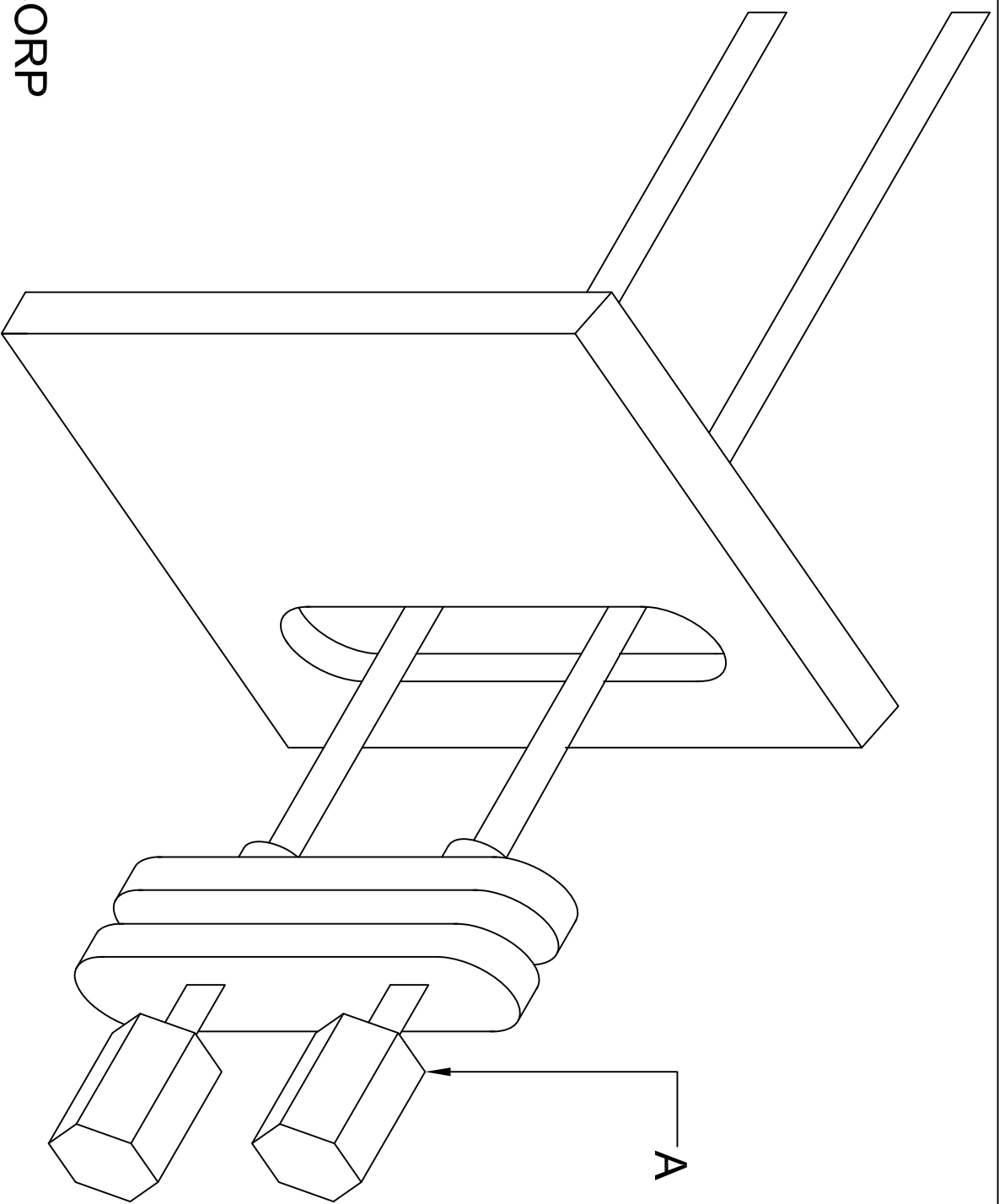

A.
 PANA PACIFIC CORP
 541 DIVISION STREET
 CAMPBELL, CALIFORNIA 95008
 408-374-7900

PART #531 277 C1

PA DEPARTMENT OF TRANSPORTATION			C.B. RADIO CONNECTIONS		
REVISIONS					
NO.	DATE	BY			
1	08-15-90	WHM			
2	07-02-97	DLW	DRAWN BY	WHM	SCALE
3	10-27-06	CJW	DATE	08-15-90	N/A
			CHECKED BY	RED	EQN-78
			SHEET 1 OF 1		

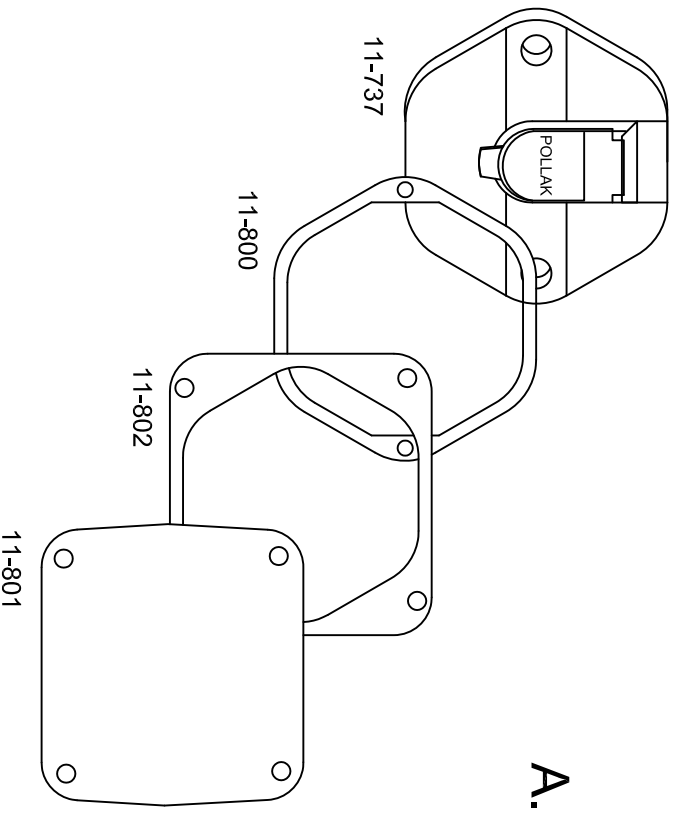

A. POLLAK / B. TRUCKLITE

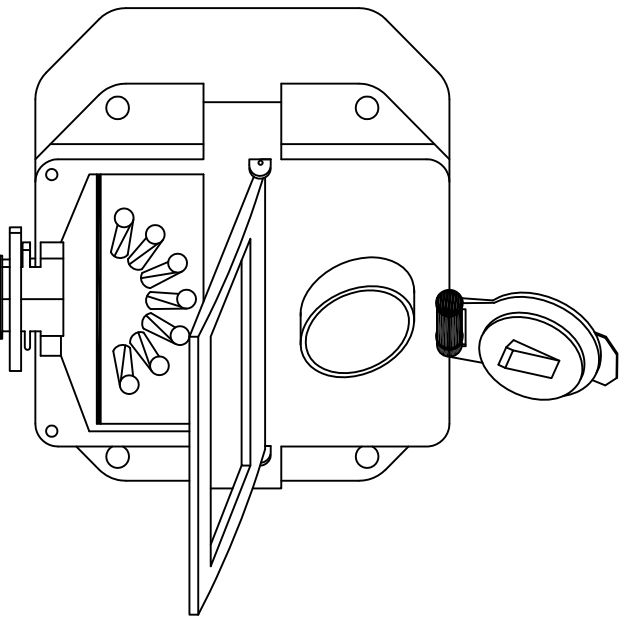

1. 7 WAY SPLIT PIN RECEPTACLE MEETING S.A.E. J5553 & J555A.
2. EXACT LOCATION SHALL BE DETERMINED UPON AWARD OF BID PRIOR TO PILOT MODEL.
3. WIRING SHALL BE IN CONFORMANCE WITH ATA COLOR CODING SYSTEM.
4. SEALED AND WEATHER-RESISTANT
5. REPLACEABLE CIRCUIT BREAKERS (15 AMP / OR 20 AMP).
6. REFERENCED ACCEPTABLE MODELS
 - A. POLLACK
 - 11-737
 - 11-800
 - 11-801
 - 11-802

(ALL ITEMS ARE REQUIRED TO MAKE UP THE COMPLETE ASSEMBLY)
 B. TRUCK-LITE PART NO. 50806-COMPLETE.

NOTE: NO SUBSTITUTE

REVISIONS				7 WAY TRAILER CONNECTOR			
NO.	DATE	BY		DATE	SCALE	CHECKED BY	SHEET
1	03-30-00	GAH		DLW	N/A	RED	EQN-81A
2	02-27-07	CJW		11-21-97			1 OF 1
3							

PA DEPARTMENT OF TRANSPORTATION

THIS VEHICLE SHALL COMPLY WITH THE RULES OF THE NATIONAL HIGHWAY TRAFFIC SAFETY ADMINISTRATION (NHTSA) IN THAT:

THE MOUNTING HEIGHT OF THE HORIZONTAL STRIPES ARE RESTRICTED TO THE SAME HEIGHT AS OTHER RETROREFLECTIVE DEVICES CURRENTLY REQUIRED BY STANDARD NUMBER 108. THE CENTER OF THE MATERIAL MUST NOT BE LESS THAN 15in. ABOVE THE ROAD SURFACE, AND THE UPPER EDGE NOT MORE THAN 60in. ABOVE IT.

REFLECTIVE MATERIAL SHALL BE APPLIED TO THE HORIZONTAL BAR OF THE REAR UNDERIDE DEVICE IN ADDITION TO THE FLOOR LEVEL HORIZONTAL STRIPE. THE UPPER CORNERS ARE TO BE MARKED BY TWO 90 DEGREE ANGLE BRACKETS OF WHITE STRIPES 12in. BY TWO INCHES WIDE, INDICATING THE WIDTH AND HEIGHT OF THE TRAILER.

THE CONFIGURATION SHALL IDENTIFY THE VEHICLE AS TO ITS ESTIMATED SIZE AND THE CLOSING DISTANCE TO IT. THE DISTRIBUTION OF SACES AND MATERIALS SHALL BE AS UNIFORM AS PRACTICAL AND INDICATE THE FULL LENGTH AND WIDTH OF THE VEHICLE. THE COLORS SHALL BE PLACED IN ALTERNATING SEQUENCE WITH MORE THAAN TWO-THIRDS OF THE MATERIAL IN COLOR.

CONSPICUITY TAPE SHALL BE REFLECTORIZED, 2in. WIDE, MATERIAL SHALL BE APPLIED. MATERIAL SHALL BE RED/SILVER CONTINUOUS BACKING REFLEXITE CONSPICUITY II SYSTEM OR 3M SCOTCHLITE CONSPICUITY SHEETING SERIES 980.

MORE CURRENT REGULATIONS SHALL BE ADHERED TO

REVISIONS			CONSPICUITY TAPE STRIPPING REQUIREMENTS		
NO	DATE	BY	DATE	SCALE	
1	05-16-02	DWG	DLW	N/A	EQN-127A
2	11-03-06	CJW			
3			DATE 11-07-97	CHK'D BY WHM	SHEET 1 OF 1

WHITE ONLY-UPPER CORNERS ARE
TWO 90 DEGREE ANGLE
BRACKETS 12" LONG x 2" WIDE

REAR OF CAB

CONSPICUITY TAPE APPLIED TO:
REAR PORTION OF FENDER OR
MUD FLAP BRACKET.

MUD FLAP

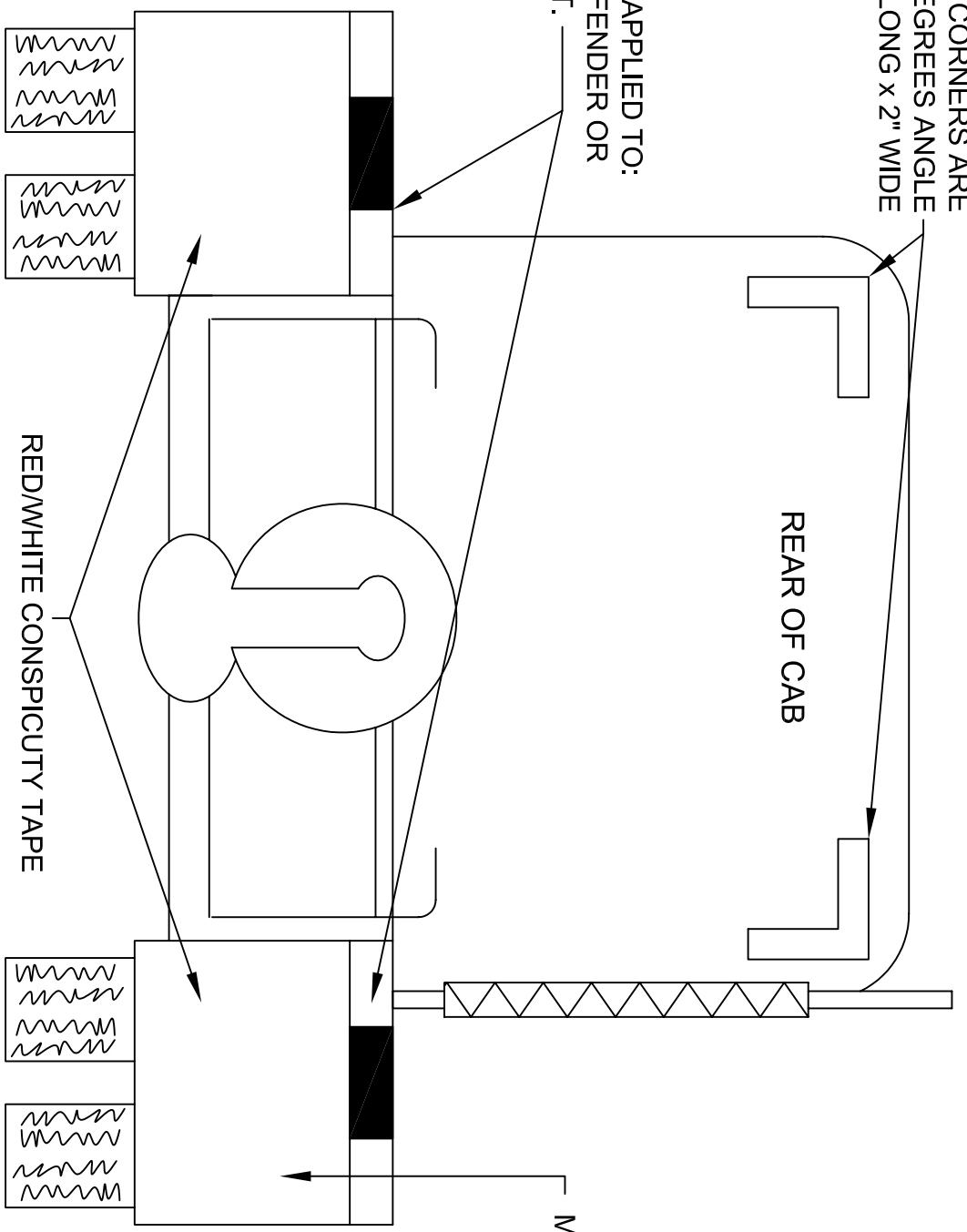

SCOTCHLITE (3M) CONSPICUITY SHEETING SERIES 980 OR
REFLEXITE CONSPICUITY II SYSTEM MATERIAL

PA DEPARTMENT OF TRANSPORTATION

**TRACTOR (LOWBOY) REAR
CONSPICUITY**

REVISIONS			TRACTOR (LOWBOY) REAR CONSPICUITY		
NO.	DATE	BY	SCALE	DRAWN BY	CHECKED BY
1	1-19-06	CJW	N/A	DJA	WHM
2					
3					

DATE 08-11-98
EQU-131
SHEET 1 OF 1

A SINGLE MAIN LINE FROM THE CENTRALLY LOCATED PUMP SUPPLIES INJECTOR MANIFOLD MODULES (AVG. OF 4) LOCATED CLOSE TO THE LUBE POINTS AS POSSIBLE. HARD PIPE SHALL BE USED WHEN / WHERE EVER POSSIBLE.

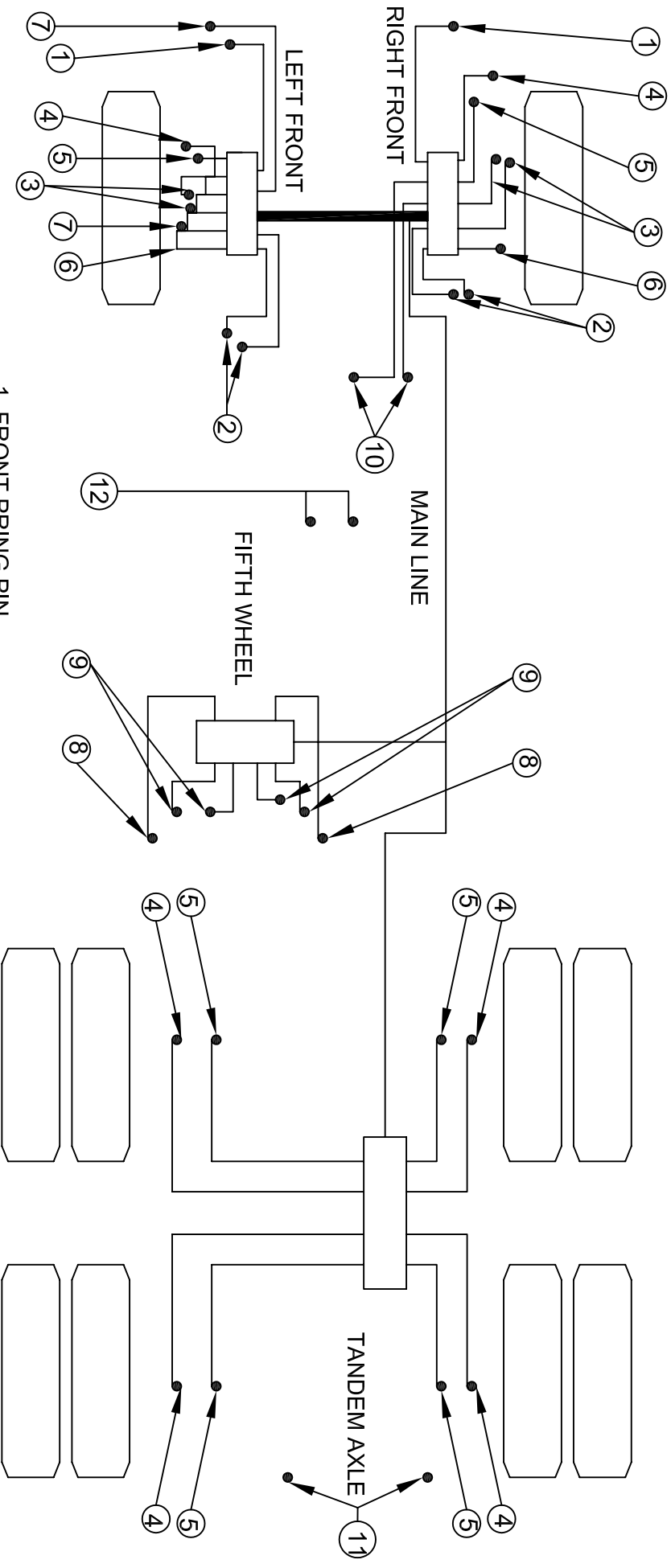

MINIMUM
TYPICAL VEHICLE
LUBE POINTS

1. FRONT PRING PIN
2. FRONT SPRING SHACKLES
(UPPER AND LOWER)
3. KING PIN (UPPER AND LOWER)
4. BRAKE CAM SHAFT
5. BRAKE SLACK ADJUSTER
6. TIE ROD
7. DRAG LINK
8. FIFTH WHEEL PIVOT
9. FIFTH WHEEL PLATE
10. CLUTCH CROSS SHAFT
11. REAR DUMP BED HINGE (2 EACH SIDE)
12. BOTTOM OF HOIST CYL. (2 EACH SIDE)

PA DEPARTMENT OF TRANSPORTATION

REVISIONS

NO.	DATE	BY	SCALE
1	12-15-00	GAH	
2	01-02-07	CJW	
3			
4			
5			

**CENTRALIZED LUBE SYSTEM
GENERIC ARRANGEMENT**

NO.	DATE	BY	SCALE
1	12-15-00	GAH	
2	01-02-07	CJW	
3			
4			
5			

DRAWN BY: GAH SCALE: N/A EQN-160
 DATE: 8-31-99 CHECKED BY: LHA SHEET 1 OF 1

SPECIFICATIONS

REVOLVING WARNING LIGHTS

THE WARNING LIGHTS DESCRIBED HERIN WILL BE USED ON OFF/ON ROAD EQUIPMENT SUCH AS CARS, TRUCKS, MOTOR GRADERS, LOADERS, ETC. REQUIRING SAFETY LIGHTS:

1. THE LIGHT SHALL OPERATE FROM A NOMINAL 12V DC POWER SOURCE. HOUSING SHALL PROVIDE RIGID SUPPORT TO THE LAMP, MOTOR, AND DRIVE TRAIN.
2. THE PRIMARY WARNING SYSTEM SHALL CONSIST OF 2 INDEPENDENT MOTOR DRIVEN PARABOLIC REFLECTORS AND A MIRROR ASSEMBLY.
3. THE MOTORS SHALL BE A HIGH TORQUE, LONG LIFE (RATED FOR 10,000 HOURS). PERMANENT MAGNET MOTOR, 12 VOLTS DC. EACH MOTOR SHALL HAVE RFI SUPPRESSION FOR RADIO FREQUENCY INTFFERENCE.
4. THE PARABOLIC REFLECTORS SHALL ROTATE AROUND A STATIONARY H1, 55-WATT HALOGEN HEAVY-DUTY LONG LIFE LAMP (RATED AT 800 HOURS PLUS). EACH PARABOLIC REFLECTOR, BULB AND MOTOR ASSEMBLY SHALL BE DESIGNED AS A SNAP IN DESIGN FOR EASY ASSEMBLY REPLACEMENT. NO FASTENERS HOLDING THIS ASSEMBLY TO THE BASE ARE ALLOWED.
5. UNIT MUST MEET SAE J845, CLASS 1 SPECIFICATIONS AND BE CERTIFIED BY AN INDEPENDENT TEST LABORATORY. THE LIGHT MUST ALSO BE CERTIFIED MY AMECA.
6. UNIT MUST BE CAPABLE OF BEING MOUNTED ON A SURFACE, OR ON A SELF-LEVELING MOUNT. ALL MOUNTING HARDWARE, INCLUDING WIRE (20FT OF 14 GAUGE), LIGHTED TOGGLE SWITCH AND ROOF MOUNTING BOLTS SHALL BE INCLUDED. A SOFT RUBBER GASKET OR MOUNTING PAD SHALL BE PROVIDED TO FORM A WEATHERPROOF SEAL BETWEEN THE HOUSING AND VEHICLE ROOF, AFFORDING MAXIMUM VIBRATION ISOLATION.

PA DEPARTMENT OF TRANSPORTATION							
REVISIONS			HIGH VOLTAGE REVOLVING WARNING LIGHT				
NO.	DATE	BY	<small>DRAWN BY</small>	DWG	<small>SCALE</small>	N/A	EQN-210B
1	07-01-03	BLD					
2	01-25-07	CJW	<small>DATE</small>	04-04-02	<small>CHKD BY</small>		SHEET 1 OF 3
3	05-29-07	KNH					

SPECIFICATIONS REVOLVING WARNING LIGHTS

7. THE LENS SHALL BE OF AMBER COLOR AND MEETS SAE 575 SPECIFICATIONS. MATERIAL MUST BE OF LENS GRADE POLYCARBONATE.

THE TOP OF THE LENS SHALL BE TEXTURED TO PREVENT SUNLIGHT FROM ENTERING AND DEGRADING THE WARNING LIGHT EFFECTIVENESS. THE SUNSCREEN SHALL ALSO PREVENT THE APPEARANCE THAT THE LIGHTBAR SIGNAL MAY BE ON DUE TO LIGHT BOUNCING OFF THE REFLECTORS AND MIRROR.

8. THE BASE OF THE LIGHTBAR SHALL BE MADE OF IMPACT-RESISTANT POLY-CARBONATE FOR NON-CORROSION.

THE LENGTH SHALL BE A MINIMUM OF 15in. AND NOT EXCEED 16in. WIDTH SHALL BE A MINIMUM OF 6in. AND NOT TO EXCEED 8in. THE HEIGHT SHALL BE A MINIMUM OF 4in.

IMPORTANT: ANY EXCEPTION TO THE ABOVE SPECIFICATIONS MUST BE CLEARLY STATED IN YOUR BID OR IT SHALL BE CONSIDERED AS "NON-RESPONSIVE".

REFERENCE: FEDERAL SIGNAL 450112-02 PDOT.

PA DEPARTMENT OF TRANSPORTATION						
REVISIONS			HIGH VOLTAGE REVOLVING WARNING LIGHT			
NO.	DATE	BY	DRAWN BY	SCALE		
1	07-01-03	BLD				
2	01-25-07	CJW	DWG	N/A	EQN-210B	
3	05-29-07	KNH	DATE	04-04-02	CHKD BY	SHEET 2 OF 3

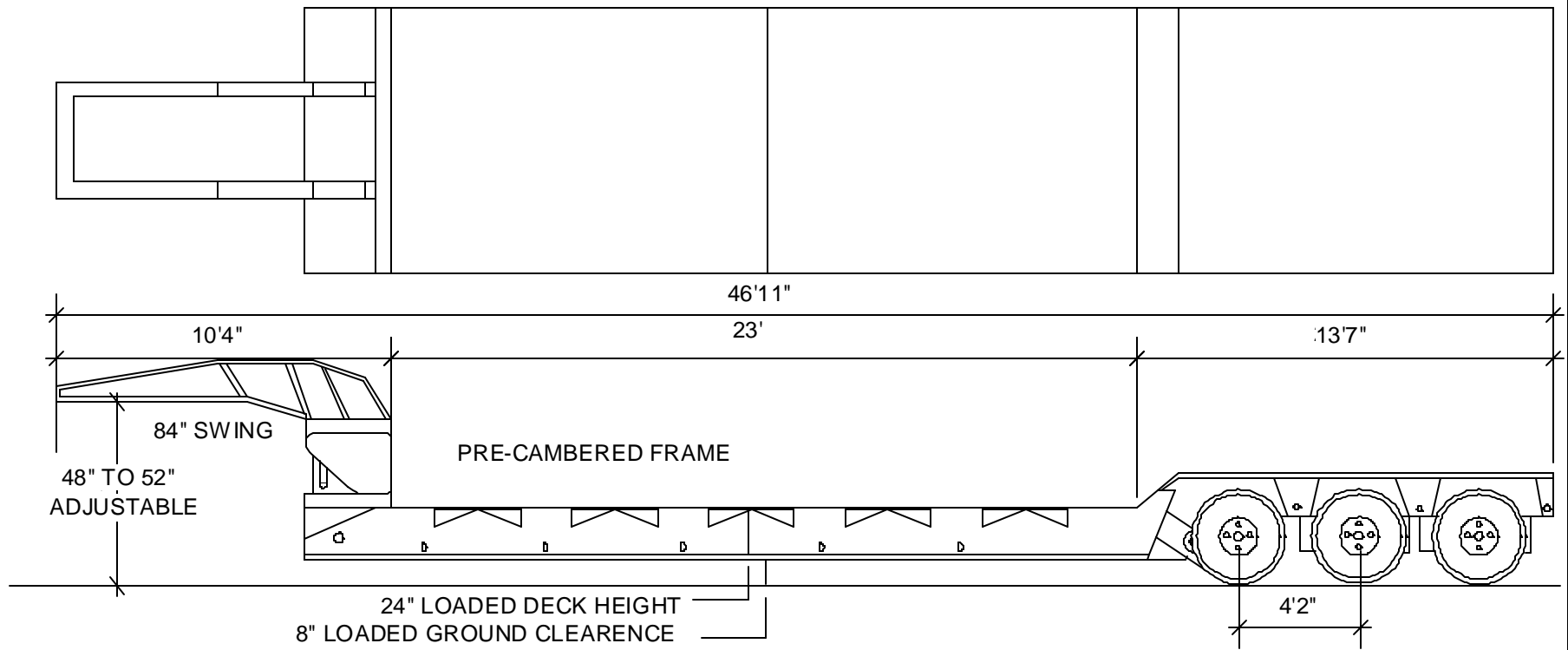

REVISIONS			COMMONWEALTH OF PENNSYLVANIA DEPARTMENT OF TRANSPORTATION		
NO.	DATE	BY	LOWBOY TRAILER FIXED THREE AXLE		
1	05/21/02	DWG			
2					
3			DRAWN BY PJC	SCALE N/A	MATERIAL
4			CHK'D LAJ	DATE 8/06/02	DRW NO. EQN - 252
5					SHEET 1 OF 1

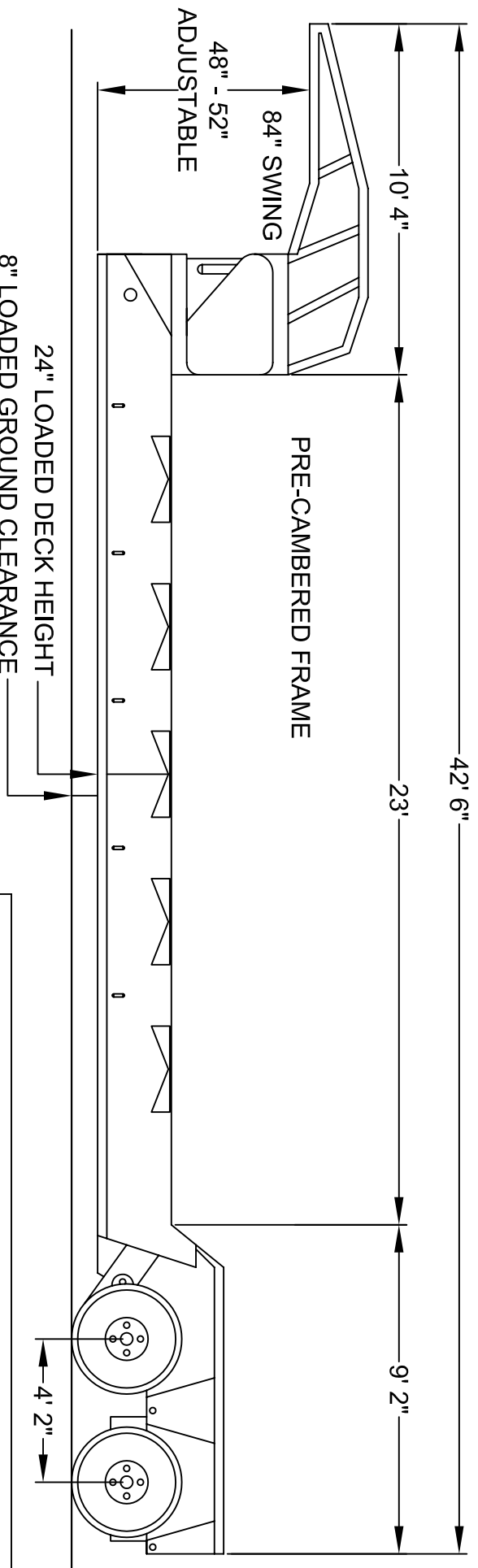
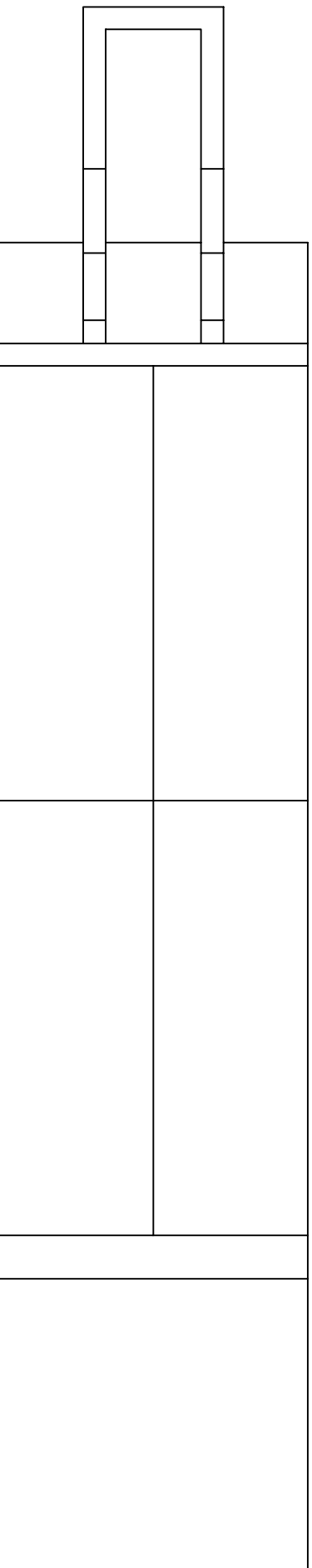

PA DEPARTMENT OF TRANSPORTATION

REVISIONS

NO.	DATE	BY	LOWBOY TRAILER TANDEM
1	02-12-07	CJW	
2			
3			
4			
5			

LOWBOY TRAILER TANDEM

DRAWN BY	PJC	SCALE	N/A
DATE	08-06-02	CHECKED BY	LAJ
			SHEET 1 OF 1

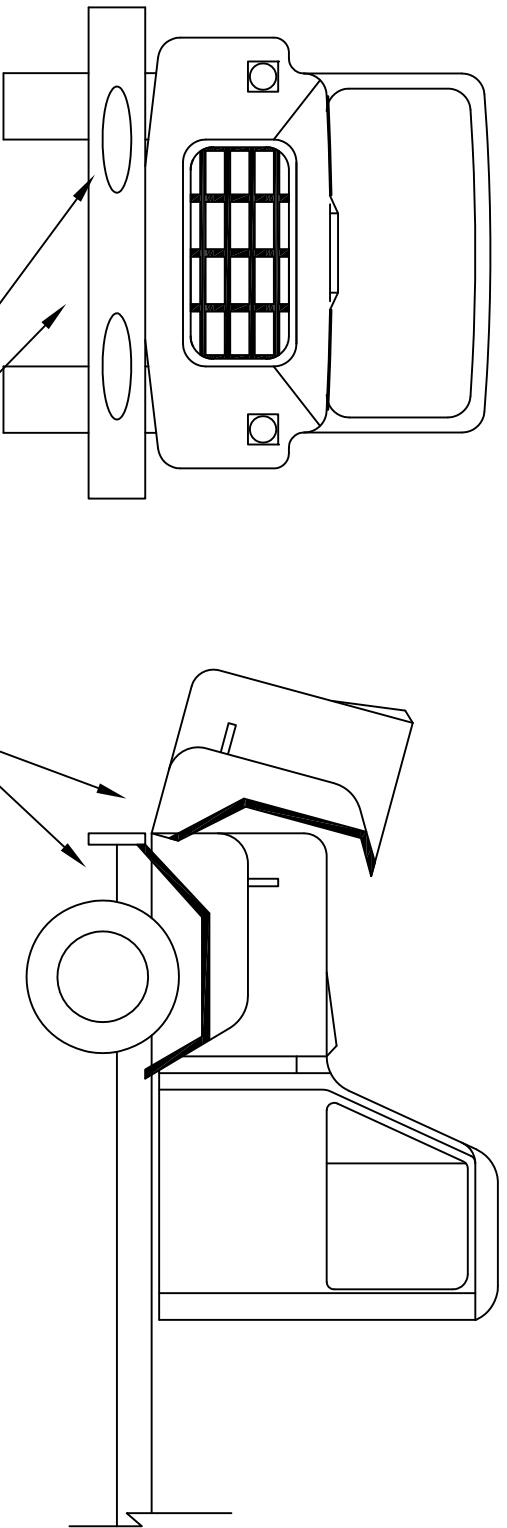

"TYPICAL"

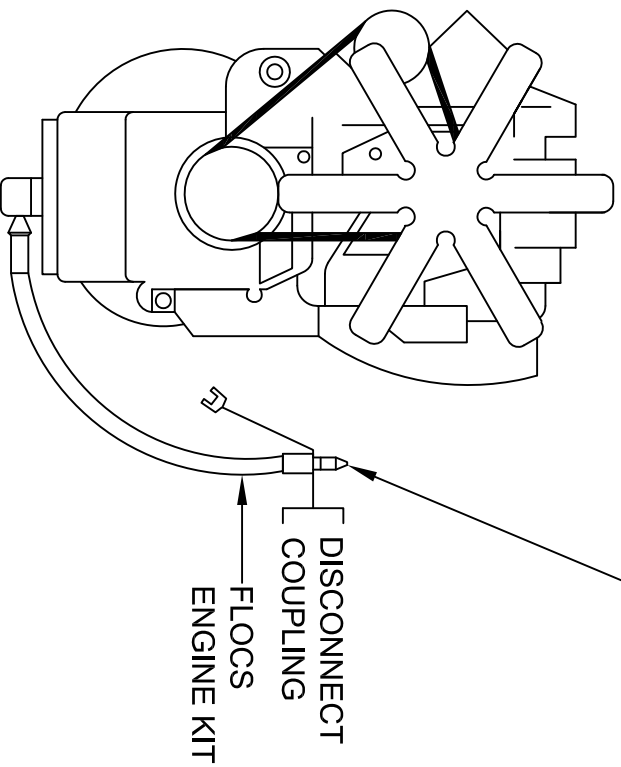

PA DEPARTMENT OF TRANSPORTATION

REVISIONS		FAST LUBE OIL CHANGE SYSTEM OVERVIEW AND PARTS LIST	
NO.	DATE	BY	SCALE
1	07-01-03	BLD	N/A
2	10-20-06	CJW	EQN-351A
3			

DATE 08-22-97 CHRG BY WHM SHEET 1 OF 2

1. CONTACT AEROQUIP WITH YOUR DRAIN PAN PLUG SIZE
2. AEROQUIP DEALER TELEPHONE NUMBERS:

- ADVANCED FLUID CONNECTORS..... 717-757-1068
- AIR BRAKE & POWER EQUIPMENT CO.. 717-622-6188
- AMERICAN BEARING & POWER..... 717-569-3291
- GOODALL RUBBER COMPANY..... 610-534-2100
- POWER DRIVES INC..... 814-833-8181
- R L MILLER INC..... 412-833-6800
- R L MILLER INC..... 814-456-8900
- SRG/BEVCO..... 610-358-3100
- VOTO MANUFACTURERS SALES CO.... 814-226-7101

FLOCS SHALL INCLUDE, BUT NOT LIMITED TO:

- A. DUST CAP 5657-12
- B. HOSE TO SUIT LENGTH
- C. HOSE FITTING TO SUIT
- D. ADAPTER TO SUIT
- E. HOSE CLAMP #900729-6
- F. BRACKET TO SUIT
- G. COUPLING 5602-12-12S

REVISIONS			FAST LUBE OIL CHANGE SYSTEM OVERVIEW AND PARTS LIST		
NO	DATE	BY	DATE	SCALE	EQN-351A
1	07-01-03	BLD			
2	10-20-06	CJW	08-22-97	N/A	
3					

PA DEPARTMENT OF TRANSPORTATION

Table of Contents

I.1 IFB-001.1 Purpose (Oct 2006)	3
I.2 IFB-005.1 Type of Contract (Oct. 2006)	3
I.3 IFB-008.1C No Pre-bid Conference (Oct. 2006)	3
I.4 IFB-009.1 Questions (Nov. 2006)	3
I.5 IFB-010.1 Addenda to the IFB (Oct. 2006).....	3
I.6 IFB-011.1B Submission of Bids – Electronic Submittal (Dec 12 2006).....	3
I.7 IFB-024.1 Bid Protest Procedure (Oct 2006)	4
I.8 IFB-025.1 Electronic Version of this IFB (Oct 2006).....	6
I.9 IFB-027.1 COSTARS Program (Dec 12 2006).....	6
I.10 IFB-029.1 Prices (Dec 6 2006).....	7
I.11 IFB-030.1 Approved Equal (Nov 2006).....	8
I.12 IFB-031.1 Alternates (Nov 2006).....	8
I.13 IFB-032.1 New Equipment (Nov 2006).....	8
I.14 I-IFB-033.1 Modification or Withdrawal of Bid (Nov 2006)	8
I.15 I-IFB-034.1 Rejection of Bids (Nov 2006)	10
II.1 IFB-006.1b COSTARS Program Questionnaire - Electronic Submission (Oct 2006)	10
II.2 II-IFB-008.1b Lobbying Certification and Disclosure – Electronic Submission. (Oct 2006)	10
II.3 IFB-009.1 Manufacturer’s Specification Order Sheet (Oct 2006).....	10
II.4 IFB-010.1 License Required (Oct 2006).....	10
II.5 IFB-011.1 Authorized Dealer/Franchiser (Oct 2006)	11
II.6 II-IFB-012.1 RETURN GOODS POLICY (NOV 2006).....	11
II.7 II-IFB-016.1 POST-SUBMISSION DESCRIPTIVE LITERATURE (Dec 2006).....	11
II.8 II-IFB-017.1b Reciprocal Limitations Act – Electronic Submittal (February 2007).....	11
III.1 III-IFB-001.1a Mandatory Responsiveness Requirements (Oct 2006)	11
III.2 III-IFB-006.1a Method of Award (Oct 2006).....	12
III.3 III-IFB-007.1 Awards (Nov 2006).....	12
III.4 III-IFB-008.1 Tie Bids (Nov 2006)	12
III.5 III-IFB-009.1 Prompt Payment Discounts (Nov 2006)	12
III.6 III-IFB-010.1 OPTION FOR SEPARATE COMPETITIVE BIDDING PROCEDURE (NOV 2006)	12
III.7 III-IFB-014.1 REBATES (Nov 2006)	12
IV.1 IFB-001.1a SPECIFICATIONS (Nov 2006).....	13
V.1 CONTRACT-001.1b Contract Terms and Conditions (Nov 30, 2006)	13
V.2 CONTRACT-002.1a Term of Contract – Contract (March 2007)	13
V.3 CONTRACT-002.1c Term of Contract – Automobiles (March 2007)	13
V.4 CONTRACT-002.2b Renewal of Contract Term – Mutual (Nov 30 2006).....	13
V.5 CONTRACT-002.3 Extension of Contract Term (Nov 30 2006)	14
V.6 CONTRACT-003.1a Signatures – Contract (March 2007)	14
V.7 CONTRACT-004.1a Definitions (Dec 12 2006).....	15
V.8 CONTRACT-005.1a Purchase Orders (Feb 2007)	15
V.9 CONTRACT-007.01a Supplies Delivery (Nov 30 2006).....	16
V.10 CONTRACT-007.01c Delivery – Automobiles (Nov 30 2006).....	16
V.11 CONTRACT-007.02 Estimated Quantities (Nov 30 2006).....	17
V.12 CONTRACT-008.1a Warranty. (Oct 2006)	17
V.13 CONTRACT-009.1c Patent, Copyright, and Trademark Indemnity (Oct 2006).....	17
V.14 CONTRACT-009.1d Ownership Rights (Oct 2006)	18
V.15 CONTRACT-010.1a Acceptance (Oct 2006).....	18
V.16 CONTRACT-011.1a Compliance With Law (Oct 2006)	19
V.17 CONTRACT-013.1 Environmental Provisions (Oct 2006).....	19
V.18 CONTRACT-014.1 Post-Consumer Recycled Content (Oct 2006)	19
V.19 CONTRACT-014.3 Enforcement (Oct 2006).....	19
V.20 CONTRACT-015.1 Compensation (Oct 2006)	19
V.21 CONTRACT-015.2 Billing Requirements (Dec 5 2006)	20
V.22 CONTRACT-015.3 Invoice Requirement – SAP Purchase Orders (Feb 2007).....	20
V.23 CONTRACT-016.1 Payment (Oct 2006)	20
V.24 CONTRACT-016.2 ACH Payments (Aug 2007)	21
V.25 CONTRACT-017.1 Taxes (Dec 5 2006).....	21

V.26 CONTRACT-018.1 Assignment of Antitrust Claims (Oct 2006)	21
V.27 CONTRACT-019.1 Hold Harmless Provision (Nov 30 2006).....	21
V.28 CONTRACT-020.1 Audit Provisions (Oct 2006)	22
V.29 CONTRACT-021.1 Default (Dec 12 2006).....	22
V.30 CONTRACT-022.1 Force Majeure (Oct 2006).....	24
V.31 CONTRACT-023.1a Termination Provisions (Oct 2006).....	24
V.32 CONTRACT-024.1 Contract Controversies (Oct 2006)	25
V.33 CONTRACT-025.1 Assignability and Subcontracting (Oct 2006).....	25
V.34 CONTRACT-026.1 Other Contractors (Oct 2006).....	26
V.35 CONTRACT-027.1 Nondiscrimination/Sexual Harassment Clause (Oct 2006).....	26
V.36 CONTRACT-028.1 Contractor Integrity Provisions (Oct 2006).....	27
V.37 CONTRACT-029.1 Contractor Responsibility Provisions (Oct 2006).....	28
V.38 CONTRACT-030.1 Americans with Disabilities Act (Oct 2006).....	29
V.39 CONTRACT-031.1 Hazardous Substances (Oct 2006)	29
V.40 CONTRACT-032.1 Covenant Against Contingent Fees (Oct 2006)	31
V.41 CONTRACT-033.1 Applicable Law (Oct 2006).....	31
V.42 CONTRACT- 034.1b Integration (Nov 30 2006).....	31
V.43 CONTRACT-034.2b Order of Precedence - IFB (Dec 6 2006)	32
V.44 CONTRACT-035.1a Changes (Oct 2006).....	32
V.45 CONTRACT-037.1b Confidentiality (Oct 2006)	32
V.46 CONTRACT-040.1b Liquidated Damages - Vehicles (Dec 6 2006)	33
V.47 CONTRACT-046.1 Manufacturer's Price Reduction (Oct 2006).....	33
V.48 CONTRACT-047.1 Motor Vehicles to be manufactured in North America (Oct 2006)	33
V.49 CONTRACT-047.2a General Requirements PennDOT Vehicles/Equipment (March 5, 2007)	33
V.50 CONTRACT-047.2b General Requirements PennDOT Vehicles/Equipment PCID NO. 1067 (Oct 2006)....	39
V.51 CONTRACT-047.3 Monthly Purchase Reports (March 5, 2007).....	39
V.52 CONTRACT-047.4 Quarterly Business Review Meetings (Oct 2006).....	40
V.53 CONTRACT-047.5 Local Public Procurement Unit Participation (March 5, 2007)	40
V.54 CONTRACT-047.6 Additional Delivery Charges (Participating Local Public Procurement Units ONLY) (Oct 2006)	40
V.55 CONTRACT-047.7 Taxes (Oct 2006).....	40
V.56 CONTRACT-047.8 Pricing Options (Oct 2006)	40
V.57 CONTRACT-051.1 Notice (Dec 2006).....	40

I.1 IFB-001.1 Purpose (Oct 2006)

The Commonwealth of Pennsylvania (Commonwealth) is issuing this Invitation for Bids (IFB) to meet the needs of DEPARTMENT OF GENERAL SERVICES to satisfy a need for **TRUCK TRACTORS, CONV CAB TANDEM**

I.2 IFB-005.1 Type of Contract (Oct. 2006)

If the Issuing Office enters into a contract as a result of this IFB, it will be a ESTABLISHED PRICE CONTRACT contract containing the Contract Terms and Conditions as shown in Part V of this IFB.

I.3 IFB-008.1C No Pre-bid Conference (Oct. 2006)

There will be no pre-bid conference for this IFB. If there are any questions, please forward them to the Issuing Office prior to the bid opening date and time.

I.4 IFB-009.1 Questions (Nov. 2006)

Any questions concerning conditions and specifications must be directed to the Issuing Office.

I.5 IFB-010.1 Addenda to the IFB (Oct. 2006)

If the Issuing Office deems it necessary to revise any part of this IFB before the bid response date, the Issuing Office will post an addendum to its website at WWW.DGS.STATE.PA.US it is the Bidder's responsibility to periodically check the website for any new information or addenda to the IFB.

I.6 IFB-011.1B Submission of Bids – Electronic Submittal (Dec 12 2006)

- a. Bids are requested for the item(s) described in the Invitation For Bids and all the documents referenced in the form (collectively called the IFB). Bidders must submit their bids through the Commonwealth's electronic system (SRM).
- b. It is the responsibility of each bidder to ensure that its Bid is received through the electronic system prior to the date and time set for the opening of bids ("Bid Opening Time"). No Bid shall be considered if it arrives after the Bid Opening Time, regardless of reason for the late arrival.

Bids that are timely received in the Bid Opening Room prior to the Bid Opening Time shall be opened publicly in the presence of one or more witnesses at the time and place designated in this IFB for the Bid opening.

- c. Bids must be firm. If a Bid is submitted with conditions or exceptions or not in conformance with the terms and conditions referenced in the IFB Form, it shall be rejected. The Bid shall also be rejected if the items offered by

the Bidder are not in conformance with the specifications as determined by the Commonwealth.

- d. The Bidder, intending to be legally bound hereby, offers and agrees, if this Bid is accepted, to provide the awarded items at the price(s) set forth in this Bid at the time(s) and place(s) specified.

I.7 IFB-024.1 Bid Protest Procedure (Oct 2006)

- a. **Who May File the Protest.** Any Bidder or prospective bidder who is aggrieved in connection with the IFB or award of the contract solicitation or award of a contract may file a protest. Protests relating to cancellation of invitations for bids and protests relating to the rejection of all bids are not permitted. A Bidder is a person that submits a bid in response to the IFB. A prospective bidder is a person that has not submitted a bid in response to the IFB.

b. **Time for Filing.**

- 1) If a protest is submitted by a prospective bidder, the protest must be filed before bid opening time or proposal receipt date.
- 2) If a protest is filed by a Bidder, the protest must be filed within seven days after the protesting Bidder knew or should have known of the facts giving rise to the protest EXCEPT THAT IN NO EVENT MAY A PROTEST BE FILED LATER THAN SEVEN (7) DAYS AFTER THE DATE THE CONTRACT OR PURCHASE ORDER WAS AWARDED. Date of filing is the date of receipt of protest.
- 3) Untimely filed protests shall be disregarded.

c. **Form of Protest.**

- 1) A protest must be in writing and filed with the agency head (or designee) of the purchasing agency.
- 2) A protest must state all grounds upon which the protesting party asserts that the solicitation or award was improper. Issues not raised by the protesting party in the protest are deemed waived and may not be raised on appeal.
- 3) The protesting party may submit with the protest any documents or information deemed relevant.

- d. **Notice of Protest** If award has been made, the agency head (or designee) shall notify the successful Bidder or contractor of the protest. If the protest is received before award and substantial issues are raised by the protest, all Bidders who appear to have a substantial and reasonable prospect of winning the award shall be notified and may file their agreement/disagreement with the purchasing agency within three (3) days after receipt of notice of the protest.

- e. **Stay of Procurement.** The head of the purchasing agency (or designee) shall immediately decide, upon receipt of the protest, whether or not the solicitation or award shall be stayed, or if the protest is timely received after the award, whether the performance of the contract should be suspended. The Issuing Office shall not proceed further with the IFB or with the award of the contract, and shall suspend performance under the contract if awarded, unless the agency head of the purchasing agency makes a written determination that the protest is clearly without merit or that award of the contract/purchase order without delay is necessary to protect the

substantial interests of the Commonwealth.

f. Procedures.

- 1) **Contracting Officer Response.** Within fifteen (15) days of the receipt of a protest, the contracting officer may submit a written response to the head of the purchasing agency (or designee). The response may include any documents or information that the contracting officer deems relevant to the protest.
- 2) **Protesting Party Reply.** Within ten (10) days of the date of the contracting officer response, the protesting party may file a written reply.
- 3) **Review.** The head of the purchasing agency (or designee) shall:
 - a) Review the protest and any response or reply.
 - b) Request and review any additional documents or information he deems necessary to render a decision.
 - c) Give the protesting party and the contracting officer reasonable opportunity to review and address any additional documents or information requested by the agency head.
 - d) In his sole discretion, conduct a hearing.
 - e) Within sixty (60) days of the receipt of the protest, issue a written determination stating the reasons for the decision.
 - f) If additional time is required to investigate the protest, inform the protesting party of the additional time needed to render a determination and obtain the protesting party's consent.
- 4) **"Clearly Without Merit" Determinations.** If the head of the purchasing agency (or designee) determines, upon receipt, that the protest is clearly without merit and does not stay the procurement, the head of the purchasing agency (or designee) shall immediately issue the decision as required by Subparagraph h below.

g. Settlement. The Issuing Office has the authority to settle and resolve bid protests.

h. Decision. The head of the purchasing agency (or designee) shall promptly, but in no event later than sixty (60) days from the filing of the protest, issue a written decision. The decision shall:

- 1) State the reasons for the decision.
- 2) If the protest is denied, inform the protesting party of its right to file an appeal in Commonwealth Court within fifteen (15) days of the mailing date of the decision.
- 3) If it is determined that the solicitation or award was contrary to law, enter an appropriate order.

The agency head (or designee) shall send a copy of the decision to the protesting party and any other person determined by the agency head (or designee) to be affected by the decision.

I.8 IFB-025.1 Electronic Version of this IFB (Oct 2006)

This IFB is being made available by electronic means. If a Bidder electronically accepts the IFB, the Bidder acknowledges and accepts full responsibility to insure that no changes are made to the IFB. In the event of a conflict between a version of the IFB in the Bidder's possession and the Issuing Office's version of the IFB, the Issuing Office's version shall govern.

I.9 IFB-027.1 COSTARS Program (Dec 12 2006)

Section 1902 of the Commonwealth Procurement Code, 62 Pa.C.S. Section 1902, authorizes local public procurement units and state-affiliated entities (together, "COSTARS Purchasers") to participate in Commonwealth procurement contracts that the Department of General Services ("DGS") may choose to make available to COSTARS Purchasers. DGS has identified this Contract as one suitable for COSTARS Purchaser participation.

A. Only those COSTARS Purchasers registered with DGS may participate as COSTARS Purchasers in a Commonwealth contract. Several thousand COSTARS Purchasers are currently registered with DGS; therefore, the Contractor agrees to permit only to DGS-registered COSTARS members to make COSTARS purchases from this Contract.

1. A "local public procurement unit" is:

- Any political subdivision;
- Any public authority;
- Any tax exempt, nonprofit educational or public health institution or organization;
- Any nonprofit fire, rescue, or ambulance company; and
- To the extent provided by law, any other entity, including a council of governments or an area government that expends public funds for the procurement of supplies, services, and construction.

2. A state-affiliated entity is a Commonwealth authority or other Commonwealth entity that is not a Commonwealth agency. The term includes the Pennsylvania Turnpike Commission, the Pennsylvania Housing Finance Agency, the Pennsylvania Municipal Retirement System, the Pennsylvania Infrastructure Investment Authority, the State Public School Building Authority, the Pennsylvania Higher Educational Facilities Authority and the State System of Higher Education.

B. COSTARS Purchasers have the option to purchase from a Contract awarded under this procurement, from any DGS contract established exclusively for COSTARS Purchasers in accordance with the requirements of Section 1902, from any other cooperative procurement contracts, or from their own procurement contracts established in accordance with the applicable laws governing such procurements. The Contractor understands and acknowledges that there is no guarantee that any prospect COSTARS Purchaser will place an order under this Contract, and that it is within the sole discretion of the registered COSTARS Purchaser whether to procure from this Contract or to use another procurement vehicle.

C. DGS is acting as a facilitator for COSTARS Purchasers who may wish to purchase under this Contract. Registered COSTARS Purchasers who participate in this Contract and issue purchase orders ("POs") to Contractors are third party beneficiaries who have the right to sue and be sued for breach of this contract without joining the Commonwealth or DGS as a party. The Commonwealth will not intervene in any action between a

Contractor and a Purchaser unless substantial interests of the Commonwealth are involved.

- D. Registered COSTARS Purchasers electing to participate in this Contract will order items directly from the Contractor and be responsible for payment directly to the Contractor.
- E. The Contractor shall furnish to the DGS COSTARS Program Office a quarterly electronic Contract sales report detailing the previous quarter's Contract purchasing activity, using the form and in the format prescribed by DGS. The Contractor shall submit its completed quarterly report no later than the fifteenth day of the succeeding Contract quarter.
1. Until such time as DGS may provide the Contractor written notice of automated report filing, the Contractor shall either e-mail the reports to GS-PACostars@state.pa.us or send the reports on compact disc via US Postal Service to the DGS COSTARS Program Office, Bureau of Procurement, 6th Floor Forum Place, 555 Walnut Street, Harrisburg, PA 17101. When DGS has instituted automated reporting, the Contractor shall comply with DGS's written notice and instructions on automated Contract reports. DGS will provide these instructions with sufficient advance time to permit the Contractor to undertake automated reporting.
 2. The Contractor shall include on each report the Contractor's name and address, the Contract number, and the period covered by the report. For each PO received, the Contractor shall include on the report the name of each COSTARS-Registered Purchaser that has used the Contract along with the total dollar volume of sales to the specific Purchaser for the reporting period.
 3. DGS may suspend the Contractor's participation in the COSTARS Program for failure to provide the Quarterly Sales Report within the specified time.
- F. Additional information regarding the COSTARS Program is available on the DGS COSTARS Website at www.dgs.state.pa.us/costars
1. If the Contractor is aware of any qualified entity not currently registered and wishing to participate in the COSTARS Program, please refer the potential purchaser to the DGS COSTARS Website at www.dgs.state.pa.us/costars, where it may register by completing the online registration form and receiving DGS confirmation of its registration. To view a list of currently-registered COSTARS member entities, please visit the COSTARS website.
 2. Direct all questions concerning the COSTARS Program to:

Department of General Services
COSTARS Program
555 Walnut Street, 6th Floor
Harrisburg, PA 17101
Telephone: 1-866-768-7827
E-mail GS-PACostars@state.pa.us

I.10 IFB-029.1 Prices (Dec 6 2006)

The bid submitted by the successful Bidder will be incorporated into any resulting Contract and the Bidder will be

required to provide the awarded item(s) at the prices quoted in its Bid.

I.11 IFB-030.1 Approved Equal (Nov 2006)

Whenever an item is defined in this IFB by trade name and catalogue number of a manufacturer or vendor, the term 'or approved equal,' if not inserted therewith shall be implied. Any reference to a particular manufacturer's product either by trade name or by limited description is solely for the purpose of more clearly indicating the minimum standard of quality desired, except where a 'no substitute' is requested. When a 'no substitute' is requested, the Issuing Office will consider Bids for the referenced product only. The term 'or approved equal' is defined as meaning any other make which, in the sole opinion of the Issuing Office, is of such character, quality, and performance equivalence as to meet the standard of quality of products specified for which it is to be used equally as well as that specified. A Bidder quoting on a product other than the referenced product shall: a) furnish complete identification in its Bid of the product it is offering by trade name, brand and/or model number; b) furnish descriptive literature and data with respect to the substitute product it proposes to furnish; and c) indicate any known specification deviations from the referenced product.

I.12 IFB-031.1 Alternates (Nov 2006)

A Bidder who wants to offer an alternate must notify the Issuing Office in writing, at least five (5) days prior to the scheduled Bid opening, that the Bidder intends to offer an alternate in its Bid. An "alternate" is a product that deviates from the requirements of the specifications in its composition, qualities, performance, size dimension, etc. The written notification from the Bidder must include a complete description of the alternate and must identify the product's deviations from the specifications. Upon receipt of the notification, the Issuing Office will determine whether the alternate is acceptable. If the Issuing Office, in its discretion, determines that the alternate is acceptable, the Issuing Office will issue a change notice to the invitation for bids that revises the specifications. If no change notice is issued revising the specification, a Bid offering the alternate will not be considered for award.

I.13 IFB-032.1 New Equipment (Nov 2006)

Unless otherwise specified in this invitation for bids, all products offered by Bidders must be new or remanufactured. A 'new' product is one that will be used first by the Commonwealth after it is manufactured or produced. A 'remanufactured' product is one which: 1) has been rebuilt, using new or used parts, to a condition which meets the original manufacturer's most recent specifications for the item; 2) does not, in the opinion of the Issuing Office, differ in appearance from a new item; and 3) has the same warranty as a new item. Unless otherwise specified in this invitation for bids, used or reconditioned products are not acceptable. This clause shall not be construed to prohibit Bidders from offering products with recycled content, provided the product is new or remanufactured.

I.14 I-IFB-033.1 Modification or Withdrawal of Bid (Nov 2006)

a. Bid Modification Prior to Bid Opening. Bids may be modified only by written notice or in person prior to the exact hour and date specified for Bid opening.

- 1) If a Bidder intends to modify its Bid by written notice, the notice must specifically identify the Bid to be modified and must be signed by the Bidder. The Bidder must include evidence of authorization for the individual who signed the modification to modify the Bid on behalf of the Bidder. The Bid modification must

be received in a sealed envelope. The sealed envelope must identify the assigned Collective Number and the Bid Opening Time, and should state that enclosed in the envelope is a Bid modification

- 2) If a Bidder intends to modify its Bid in person, the individual who will modify the Bid must arrive in the Bid Opening Room prior to the Bid Opening Time, show a picture identification and provide evidence of his/her authorization to modify the Bid on behalf of the Bidder. If a Bidder intends to modify its Bid in person, the Bidder may do so only in the presence of an agency employee. (The agency employee will observe the actions taken by the individual to modify the Bid, but will not read the Bid or the modification).

b. Bid Withdrawal Prior to Bid Opening. Bids may be withdrawn only by written notice or in person prior to the exact hour and date specified for Bid opening.

- 1) If a Bidder intends to withdraw its Bid by written notice, the notice shall specifically identify the Bid to be withdrawn and shall be signed by the Bidder. The Bidder must include evidence of authorization for the individual who signed the bid withdrawal to withdraw the bid on behalf of the Bidder. Except as provided in Subparagraph c, below, bid withdrawals received after the exact hour and date specified for the receipt of Bids shall not be accepted.
- 2) If a Bidder intends to withdraw its Bid in person, the individual who will withdraw the Bid must arrive in the Bid Opening Room prior to the Bid Opening Time, show a picture identification and provide evidence of his/her authorization to withdraw the Bid on behalf of the Bidder.

c. Bid Withdrawal After Bid Opening. Bidders are permitted to withdraw erroneous Bids after Bid opening only if the following conditions are met:

- 1) The Bidder submits a written request for withdrawal.
- 2) The Bidder presents credible evidence with the request that the reason for the lower Bid price was a clerical mistake as opposed to a judgment mistake and was actually due to an unintentional arithmetical error or an unintentional omission of a substantial quantity of work, labor, material, or services made directly in the compilation of the Bid.
- 3) The request for relief and supporting evidence must be received by the Issuing Office within three (3) business days after Bid opening, but before award of the contract.
- 4) The Issuing Office shall not permit a Bid withdrawal if the Bid withdrawal would result in the award of the contract on another Bid of the same Bidder, its partner, or a corporation or business venture owned by or in which the bidder has a substantial interest.
- 5) If a Bidder is permitted to withdraw its Bid, the Bidder cannot supply any material or labor or perform any subcontract or other work agreement for the awarded contractor, without the written approval of the Issuing Office.

d. Firm Bid. Except as provided above, a Bid may not be modified, withdrawn, or cancelled by any Bidder for a period of sixty (60) days following the time and date designated for Bid opening, unless otherwise specified by the Bidder in its Bid. If the lowest responsible Bidder, as determined by the Issuing Office, withdraws its Bid prior to the expiration of the award period or fails to comply with the requirements set forth in the IFB including but not limited to any requirement to submit performance or payment bonds or insurance certificates within the required time period, the Bidder shall be liable to the Commonwealth for all costs and damages associated with the re-award or re-bid including the difference between the Bidder's price and the actual cost that the

Commonwealth pays for the awarded items.

e. Clarification and Additional Information. After the receipt of Bids, the Issuing Office shall have the right to contact Bidders for the purpose of seeking:

- 1) Clarification of the Bid which confirms the Issuing Office's understanding of statements or information in the Bid or;
- 2) Additional information on the items offered; provided the IFB does not require the rejection of the Bid for failure to include such information.

I.15 I-IFB-034.1 Rejection of Bids (Nov 2006)

The Issuing Office reserves the right to reject any and all Bids, to waive technical defects or any informality in Bids, and to accept or reject any part of any Bid if the best interests of the Commonwealth are thereby served.

II.1 IFB-006.1b COSTARS Program Questionnaire - Electronic Submission (Oct 2006)

Offerors should complete and submit the COSTARS Program Questionnaire Form, which is attached to and made a part of this IFB, and submit it with its proposal. The completed COSTARS Program Questionnaire Form should be submitted as part of the Bid Response.

II.2 II-IFB-008.1b Lobbying Certification and Disclosure – Electronic Submission. (Oct 2006).

With respect to an award of a federal contract, grant, or cooperative agreement exceeding \$100,000 or an award of a federal loan or a commitment providing for the United States to insure or guarantee a loan exceeding \$150,000 all recipients must certify that they will not use federal funds for lobbying and must disclose the use of non-federal funds for lobbying by filing required documentation. Offerors must complete and return the Lobbying Certification Form and the Disclosure of Lobbying Activities Form, which are attached to and made a part of this IFB. The completed and signed Lobbying Certification Form and the Disclosure of Lobbying Activities Form should be submitted with the Bid Response. Commonwealth agencies will not contract with outside firms or individuals to perform lobbying services, regardless of the source of funds.

II.3 IFB-009.1 Manufacturer's Specification Order Sheet (Oct 2006)

The Manufacturer's Specification Order Sheet must accompany the bid and must indicate all standard equipment plus available interior/exterior color combinations. At the time of award, these sheets will be posted on DGS's website which should alleviate the number of telephone calls from the ordering agencies to the Contractor requesting such. **Failure to provide the Manufacturer's Specification Order Sheet may result in rejection of the proposal.**

II.4 IFB-010.1 License Required (Oct 2006)

It is unlawful for any individual, corporation, partnership, association or other entity foreign or domestic to engage in the business of salesperson, broker, dealer, manufacturer, factory branch, distributor, distributor branch, factory or distributor representative or wholesaler within COMMONWEALTH unless he has secured a license as required by Act No. 84 of 1983, known as the Board of Vehicles Act. Before a Contract is awarded to any bidder and before a bidder sells COMMONWEALTH any vehicle covered by this requisition, he must hold or secure an appropriate license issued by the State Board of Vehicle Manufacturers, Dealers and Salespersons. Information and/or an application in regard to the license requirement can be obtained from:

Department of State
Bureau of Professional and Occupational Affairs
State Board of Motor Vehicle Manufacturers, Dealers and Salesmen
P.O. Box 2649
Harrisburg, PA 17105-2649

Out-Of-State Dealers are not required to secure a license under Act No. 84 of 1983, and therefore, do not need to comply with this "License Required" Section. If you are a PA Dealer, please submit your license number with your proposal.

II.5 IFB-011.1 Authorized Dealer/Franchiser (Oct 2006)

In order to be eligible for award, an offeror must be an Authorized/Franchised dealer representing the manufacturer of Vehicles offered to the Commonwealth.

II.6 II-IFB-012.1 RETURN GOODS POLICY (NOV 2006)

Each bidder must submit a copy of their return goods policy with their bid.

II.7 II-IFB-016.1 POST-SUBMISSION DESCRIPTIVE LITERATURE (Dec 2006)

The Commonwealth may, during its evaluation of the bids, require any bidder to submit cuts, illustrations, drawings, prints, test data sheets, specification sheets and brochures which detail construction features, design, components, materials used, applicable dimensions and any other pertinent information which the Issuing Office may require in order to evaluate the product(s) offered. The required information must be submitted within two (2) business days after notification from the Issuing Office. Failure to submit the required information prior to the expiration of the second business day after notification shall result in the rejection of the bid as non-responsive.

II.8 II-IFB-017.1b Reciprocal Limitations Act – Electronic Submittal (February 2007)

This procurement is subject to the Reciprocal Limitations Act. Bidders must complete and submit with the Bid Response the State of Manufacture Chart, which is contained in GSPUR-89 ("Reciprocal Limitations Act Requirements") which is attached to and made part of this IFB. The completed State of Manufacture Chart should be submitted as part of the Bid Reponse

III.1 III-IFB-001.1a Mandatory Responsiveness Requirements (Oct 2006)

To be eligible for selection, a bid must be:

- a. Timely received from a Bidder;
- b. Properly signed by the Bidder.

III.2 III-IFB-006.1a Method of Award (Oct 2006)

It is the intent of the Commonwealth to make a single award of item(s) listed in the IFB. The Commonwealth reserves the right to award by line item if it determines that it is in the best interest of the Commonwealth to do so.

III.3 III-IFB-007.1 Awards (Nov 2006)

Unless all Bids are rejected, and except as otherwise provided by law, award will be made, through the issuance of a Purchase Order, to the lowest responsible and responsive Bidder. Unless otherwise specified by the Issuing Office in the IFB form the Commonwealth reserves the right to award by item or on a total Bid basis, whichever is deemed more advantageous to the Commonwealth. In cases of discrepancies in prices, the unit price will be binding unless the unit price is obviously in error and the extended price is obviously correct, in which case the erroneous unit price will be corrected. As a condition for receipt of award of a contract/purchase order, the lowest responsible and responsive Bidder must be registered in the Commonwealth of Pennsylvania's Vendor Master file. In order to register, bidders must visit the PA Supplier Portal at <https://www.pasupplierportal.state.pa.us/> or call the Customer Support Center at 877-435-7363 or 717-346-2676.

III.4 III-IFB-008.1 Tie Bids (Nov 2006)

All tie bids will be broken by the Issuing Office.

III.5 III-IFB-009.1 Prompt Payment Discounts (Nov 2006)

Prompt payment discounts will not be considered in making an award. If prompt payment discounts are offered by any Bidder, however, the Issuing Office will take advantage of such offer.

III.6 III-IFB-010.1 OPTION FOR SEPARATE COMPETITIVE BIDDING PROCEDURE (NOV 2006)

The Commonwealth reserves the right to purchase products or services covered under this Contract through a separate competitive bidding procedure, whenever Commonwealth deems it in the best interest of the Commonwealth. The right will generally be exercised only when a specific need for a large quantity of the product or service exists or when the price offered is significantly lower than the Contract price.

III.7 III-IFB-014.1 REBATES (Nov 2006)

Any rebate applicable at the time of bid should be taken into consideration by the bidder in calculating its bid price. Bidders must specifically state in their bid proposal, when applicable, that rebates have been considered in arriving at the bid price. Following award, the Commonwealth will assign to the awarded bidder, any rebates which the bidder stated that he took into consideration. If the bidder fails to include such a statement, the Commonwealth will receive the full benefit of the manufacturer's rebate.

IV.1 IFB-001.1a SPECIFICATIONS (Nov 2006)

The Commonwealth is seeking bids to procure the item(s) set forth in the attached document entitled "Specifications."

V.1 CONTRACT-001.1b Contract Terms and Conditions (Nov 30, 2006)

The Contract with the awarded bidder (who shall become the "Contractor") shall include the following terms and conditions:

V.2 CONTRACT-002.1a Term of Contract – Contract (March 2007)

- a. The term of the Contract shall begin on the Commencement Date (as defined below) and shall end on the Expiration Date identified in the Contract, subject to the other provisions of the Contract.
- b. The Commencement Date shall be the later of the "Valid from" date shown on the Contract output form or the Effective Date (as defined below).
- c. The Effective Date shall be the Effective Date printed on the Contract output form after the Contract has been fully executed by the Commonwealth (fully executed by the Commonwealth means that it has been signed and approved as required by Commonwealth contracting procedures).

V.3 CONTRACT-002.1c Term of Contract – Automobiles (March 2007)

- a. The term of the Contract shall begin on the Commencement Date (as defined below) and shall end on the Expiration Date identified in the Contract, subject to the other provisions of the Contract.
- b. The Commencement Date shall be the later of the "Valid from" date shown on the Contract output form or the Effective Date (as defined below).
- c. The Effective Date shall be the Effective Date printed on the Contract output form after the Contract has been fully executed by the Commonwealth (fully executed by the Commonwealth means that it has been signed and approved as required by Commonwealth contracting procedures).
- d. The Contractor shall not be contractually obligated to supply when the Contractor's stock is depleted and cannot be restocked by manufacturer.

V.4 CONTRACT-002.2b Renewal of Contract Term – Mutual (Nov 30 2006)

The Contract may be mutually renewed for a maximum of 4 additional 1 year term(s), so long as the Commonwealth provides written notice to Contractor of its intention to extend the Contract by letter dated not less

than 090 days prior to the expiration of the term of the agreement, or any extension thereof, and the Contractor consents to the renewal not less than 060 days prior to the expiration of the term of the agreement or any extension thereof. The renewal may be exercised as individual or multiple year terms(s). Any renewal will be under same terms, covenants and conditions. No further document is required to be executed to renew the term of the contract.

V.5 CONTRACT-002.3 Extension of Contract Term (Nov 30 2006)

The Commonwealth reserves the right, upon notice to the Contractor, to extend any single term of the Contract for up to three (3) months upon the same terms and conditions.

V.6 CONTRACT-003.1a Signatures – Contract (March 2007)

The Contract shall not be a legally binding contract until the fully-executed Contract has been sent to the Contractor. No Commonwealth employee has the authority to verbally direct the commencement of any work or delivery of any supply under this Contract prior to the Effective Date. The Contractor hereby waives any claim or cause of action for any service or work performed prior to the Effective Date.

The Contract will not include an "ink" signature by the Commonwealth. The electronically-printed name of the Purchasing Agent represents the signature of that individual who has the authority, on behalf of the Commonwealth, to bind the Commonwealth to the terms of the Contract. If the Contract output form does not have "Fully Executed" at the top of the first page and does not have the name of the Purchasing Agent printed in the appropriate box, the Contract has not been fully executed.

The fully-executed Contract may be sent to the Contractor electronically or through facsimile equipment. The electronic transmission of a purchase order shall require acknowledgement of receipt of the transmission by the Contractor. Receipt of the electronic or facsimile transmission of the Contract shall constitute receipt of the fully-executed Contract.

The Commonwealth and the Contractor specifically agree as follows:

- a. No handwritten signature shall be required in order for the Contract to be legally enforceable.
- b. The parties agree that no writing shall be required in order to make the Contract legally binding, notwithstanding contrary requirements in any law. The parties hereby agree not to contest the validity or enforceability of a genuine Contract or acknowledgement issued electronically under the provisions of a statute of frauds or any other applicable law relating to whether certain agreements be in writing and signed by the party bound thereby. Any genuine Contract or acknowledgement issued electronically, if introduced as evidence on paper in any judicial, arbitration, mediation, or administrative proceedings, will be admissible as between the parties to the same extent and under the same conditions as other business records originated and maintained in documentary form. Neither party shall contest the admissibility of copies of a genuine Contract or acknowledgements under either the business records exception to the hearsay rule or the best evidence rule on the basis that the Contract or acknowledgement were not in writing or signed by the parties. A Contract or acknowledgment shall be deemed to be genuine for all purposes if it is transmitted to the location designated for such documents.

c. Each party will immediately take steps to verify any document that appears to be obviously garbled in transmission or improperly formatted to include re-transmission of any such document if necessary.

V.7 CONTRACT-004.1a Definitions (Dec 12 2006)

As used in this Contract, these words shall have the following meanings:

- a. Agency The department, board, commission or other agency of the Commonwealth of Pennsylvania listed as the Purchasing Agency. If a COSTARS entity or external procurement activity has issued an order against this contract, that entity shall also be identified as "Agency".
- b. Contracting Officer The person authorized to administer this Contract for the Commonwealth and to make written determinations with respect to the Contract.
- c. Days Unless specifically indicated otherwise, days mean calendar days.
- d. Developed Works or Developed Materials All documents, sketches, drawings, designs, works, papers, files, reports, computer programs, computer documentation, data, records, software, samples or any other tangible material without limitation authored or prepared by Contractor as the work product covered in the scope of work for the Project.
- e. Documentation All materials required to support and convey information about the services required by this Contract. It includes, but is not necessarily restricted to, written reports and analyses, diagrams, maps, logical and physical designs, system designs, computer programs, flow charts, disks, and/or other machine-readable storage media.
- f. Services All Contractor activity necessary to satisfy the Contract.

V.8 CONTRACT-005.1a Purchase Orders (Feb 2007)

Commonwealth agencies may issue Purchase Orders against the Contract. These orders constitute the Contractor's authority to make delivery. All Purchase Orders received by the Contractor up to and including the expiration date of the Contract are acceptable and must be performed in accordance with the Contract. Each Purchase Order will be deemed to incorporate the terms and conditions set forth in the Contract.

Purchase Orders will not include an "ink" signature by the Agency. The electronically-printed name of the purchaser represents the signature of that individual who has the authority, on behalf of the Commonwealth, to authorize the Contractor to proceed.

Purchase Orders may be issued electronically or through facsimile equipment. The electronic transmission of a purchase order shall require acknowledgement of receipt of the transmission by the Contractor. Receipt of the electronic or facsimile transmission of the Purchase Order shall constitute receipt of an order. Orders received by the Contractor after 4:00 p.m. will be considered received the following business day.

a. No handwritten signature shall be required in order for the Contract or Purchase Order to be legally enforceable.

b. The parties agree that no writing shall be required in order to make the order legally binding. The parties hereby agree not to contest the validity or enforceability of a Purchase Order or acknowledgement issued electronically under the provisions of a statute of frauds or any other applicable law relating to whether certain agreements be in writing and signed by the party bound thereby. Any Purchase Order or acknowledgement issued electronically, if introduced as evidence on paper in any judicial, arbitration, mediation, or administrative proceedings, will be admissible as between the parties to the same extent and under the same conditions as other business records originated and maintained in documentary form. Neither party shall contest the admissibility of copies of Purchase Orders or acknowledgements under either the business records exception to the hearsay rule or the best evidence rule on the basis that the order or acknowledgement were not in writing or signed by the parties. A purchase order or acknowledgment shall be deemed to be genuine for all purposes if it is transmitted to the location designated for such documents.

c. Each party will immediately take steps to verify any document that appears to be obviously garbled in transmission or improperly formatted to include re-transmission of any such document if necessary.

Purchase Orders under five thousand dollars (\$5,000) in total amount may also be made in person or by telephone using a Commonwealth Purchasing Card. When an order is placed by telephone, the Commonwealth agency shall provide the agency name, employee name, credit card number, and expiration date of the card. Contractors agree to accept payment through the use of the Commonwealth Purchasing Card.

V.9 CONTRACT-007.01a Supplies Delivery (Nov 30 2006)

All item(s) shall be delivered F.O.B. Destination. The Contractor agrees to bear the risk of loss, injury, or destruction of the item(s) ordered prior to receipt of the items by the Commonwealth. Such loss, injury, or destruction shall not release the Contractor from any contractual obligations. Except as otherwise provided in this contract, all item(s) must be delivered within the time period specified. Time is of the essence and, in addition to any other remedies, the Contract is subject to termination for failure to deliver as specified. Unless otherwise stated in this Contract, delivery must be made within thirty (30) days after the Effective Date.

V.10 CONTRACT-007.01c Delivery – Automobiles (Nov 30 2006)

The Contractor(s) must make delivery no later than 300 calendar days after acknowledgement of purchase order for TRUCK TRACTORS . Failure to deliver within these time periods shall result in payment of liquidated damages in accordance with Paragraph 17, of these Special Terms and Conditions. Liquidated damages shall not apply under the circumstances specified in Paragraph 20, Force Majeure, of the Standard Contract Terms and Conditions For Statewide Contracts for Supplies.

CWOPA understands that the Contractor is not obligated to deliver orders placed after the Original Equipment Manufacturer (OEM) build-out date, if vehicles are not available.

Vehicles purchased by the Pennsylvania State Police will be delivered FOB to: Pennsylvania State Police, Transportation Division, 20th & Herr Sts., Harrisburg, PA 17103 Contact person is Rick Binker, Director at 717-787-1318.

Vehicles purchased by Pennsylvania Department of Transportation will be delivered FOB to: PA Department of Transportation, Equipment Division, 17th & Arsenal Blvd., Harrisburg, PA 17120 Prior to delivery the Contractor must contact Larry Allen at 717-787-2123, for inspection appointment, title, and MV1 instructions.

Vehicles purchased by Pennsylvania Turnpike Commission will be delivered FOB to:

Pennsylvania Turnpike Maintenance Facility, Milepost 243.8 (New Cumberland), 519 Marsh Run Road, New Cumberland, PA17070 Contact Phone Number: (717) 939-9551 ext. 5100

MAILING ADDRESS*:

Pennsylvania Turnpike Commission
Route 283
P.O. Box 67676
Harrisburg, PA17106

All other vehicles will be delivered FOB to: DGS, Bureau of Vehicle Management, 2221 Forster St., Harrisburg, PA 17125, with all proper paperwork as stated in the body of the specification sheets.

Prior to deliveries with the exception of the Pennsylvania Department of Transportation, the Contractor must contact Mickey Morrow with DGS, at 717-787-4252, for inspection appointment, title, and MV1 instructions.

During the term of the Contract, CWOPA reserves the right to work with the Contractor(s) to identify additional delivery locations across the CWOPA. Additional delivery costs, if any, will be determined through negotiations with the Contractor(s).

V.11 CONTRACT-007.02 Estimated Quantities (Nov 30 2006)

It shall be understood and agreed that any quantities listed in the Contract are estimated only and may be increased or decreased in accordance with the actual requirements of the Commonwealth and that the Commonwealth in accepting any bid or portion thereof, contracts only and agrees to purchase only the materials and services in such quantities as represent the actual requirements of the Commonwealth. The Commonwealth reserves the right to purchase materials and services covered under the Contract through a separate competitive procurement procedure, whenever Commonwealth deems it to be in its best interest.

V.12 CONTRACT-008.1a Warranty. (Oct 2006)

The Contractor warrants that all items furnished and all services performed by the Contractor, its agents and subcontractors shall be free and clear of any defects in workmanship or materials. Unless otherwise stated in the Contract, all items are warranted for a period of one year following delivery by the Contractor and acceptance by the Commonwealth. The Contractor shall repair, replace or otherwise correct any problem with the delivered item. When an item is replaced, it shall be replaced with an item of equivalent or superior quality without any additional cost to the Commonwealth.

V.13 CONTRACT-009.1c Patent, Copyright, and Trademark Indemnity (Oct 2006)

The Contractor warrants that it is the sole owner or author of, or has entered into a suitable legal agreement concerning either: a) the design of any product or process provided or used in the performance of the Contract which is covered by a patent, copyright, or trademark registration or other right duly authorized by state or federal law or b) any copyrighted matter in any report document or other material provided to the Commonwealth under the contract.

The Contractor shall defend any suit or proceeding brought against the Commonwealth on account of any alleged patent, copyright or trademark infringement in the United States of any of the products provided or used in the performance of the Contract.

This is upon condition that the Commonwealth shall provide prompt notification in writing of such suit or proceeding; full right, authorization and opportunity to conduct the defense thereof; and full information and all reasonable cooperation for the defense of same.

As principles of governmental or public law are involved, the Commonwealth may participate in or choose to conduct, in its sole discretion, the defense of any such action.

If information and assistance are furnished by the Commonwealth at the Contractor's written request, it shall be at the Contractor's expense, but the responsibility for such expense shall be only that within the Contractor's written authorization.

The Contractor shall indemnify and hold the Commonwealth harmless from all damages, costs, and expenses, including attorney's fees that the Contractor or the Commonwealth may pay or incur by reason of any infringement or violation of the rights occurring to any holder of copyright, trademark, or patent interests and rights in any products provided or used in the performance of the Contract.

If any of the products provided by the Contractor in such suit or proceeding are held to constitute infringement and the use is enjoined, the Contractor shall, at its own expense and at its option, either procure the right to continue use of such infringement products, replace them with non-infringement equal performance products or modify them so that they are no longer infringing.

If the Contractor is unable to do any of the preceding, the Contractor agrees to remove all the equipment or software which are obtained contemporaneously with the infringing product, or, at the option of the Commonwealth, only those items of equipment or software which are held to be infringing, and to pay the Commonwealth: 1) any amounts paid by the Commonwealth towards the purchase of the product, less straight line depreciation; 2) any license fee paid by the Commonwealth for the use of any software, less an amount for the period of usage; and 3) the pro rata portion of any maintenance fee representing the time remaining in any period of maintenance paid for. The obligations of the Contractor under this paragraph continue without time limit. No costs or expenses shall be incurred for the account of the Contractor without its written consent.

V.14 CONTRACT-009.1d Ownership Rights (Oct 2006)

The Commonwealth shall have unrestricted authority to reproduce, distribute, and use any submitted report, data, or material, and any software or modifications and any associated documentation that is designed or developed and delivered to the Commonwealth as part of the performance of the Contract.

V.15 CONTRACT-010.1a Acceptance (Oct 2006)

No item(s) received by the Commonwealth shall be deemed accepted until the Commonwealth has had a reasonable opportunity to inspect the item(s). Any item(s) which is discovered to be defective or fails to conform to the specifications may be rejected upon initial inspection or at any later time if the defects contained in the item(s) or the noncompliance with the specifications were not reasonably ascertainable upon the initial inspection. It shall thereupon become the duty of the Contractor to remove rejected item(s) from the premises without expense to the Commonwealth within fifteen (15) days after notification. Rejected item(s) left longer than fifteen (15) days will be regarded as abandoned, and the Commonwealth shall have the right to dispose of them as its own property and shall retain that portion of the proceeds of any sale which represents the Commonwealth's costs and expenses in regard to the storage and sale of the item(s). Upon notice of rejection, the Contractor shall immediately replace all such rejected item(s) with others conforming to the specifications and which are not defective. If the Contractor fails, neglects or refuses to do so, the Commonwealth shall then have the right to procure a corresponding quantity of such item(s), and deduct from any monies due or that may thereafter become due to the Contractor, the difference between the price stated in the Contract and the cost thereof to the Commonwealth.

V.16 CONTRACT-011.1a Compliance With Law (Oct 2006)

The Contractor shall comply with all applicable federal and state laws and regulations and local ordinances in the performance of the Contract.

V.17 CONTRACT-013.1 Environmental Provisions (Oct 2006)

In the performance of the Contract, the Contractor shall minimize pollution and shall strictly comply with all applicable environmental laws and regulations, including, but not limited to: the Clean Streams Law Act of June 22, 1937 (P.L. 1987, No. 394), as amended 35 P.S. Section 691.601 et seq.; the Pennsylvania Solid Waste Management Act, Act of July 7, 1980 (P.L. 380, No. 97), as amended, 35 P.S. Section 6018.101 et seq.; and the Dam Safety and Encroachment Act, Act of November 26, 1978 (P.L. 1375, No. 325), as amended, 32 P.S. Section 693.1.

V.18 CONTRACT-014.1 Post-Consumer Recycled Content (Oct 2006)

Except as specifically waived by the Department of General Services in writing, any products which are provided to the Commonwealth as a part of the performance of the Contract must meet the minimum percentage levels for total recycled content as specified on the Department of General Services website at WWW.DGS.STATE.PA.US on the date of submission of the bid, proposal or contract offer.

V.19 CONTRACT-014.3 Enforcement (Oct 2006)

The Contractor may be required, after delivery of the Contract item(s), to provide the Commonwealth with documentary evidence that the item(s) was in fact produced with the required minimum percentage of post-consumer and recovered material content.

V.20 CONTRACT-015.1 Compensation (Oct 2006)

The Contractor shall be required to furnish the awarded item(s) at the price(s) quoted in the Purchase Order. All item(s) shall be delivered within the time period(s) specified in the Purchase Order. The Contractor shall be compensated only for item(s) that are delivered and accepted by the Commonwealth.

V.21 CONTRACT-015.2 Billing Requirements (Dec 5 2006)

The Contractor shall include in all of its invoices the following minimum information:

- Vendor name and "Remit to" address, including SAP Vendor number;
- Bank routing information, if ACH;
- SAP Purchase Order number;
- Delivery Address, including name of Commonwealth agency;
- Description of the supplies/services delivered in accordance with SAP Purchase Order (include purchase order line number if possible);
- Quantity provided;
- Unit price;
- Price extension;
- Total price; and
- Delivery date of supplies or services.

If an invoice does not contain the minimum information set forth in this paragraph, the Commonwealth may return the invoice as improper. If the Commonwealth returns an invoice as improper, the time for processing a payment will be suspended until the Commonwealth receives a correct invoice. The Contractor may not receive payment until the Commonwealth has received a correct invoice.

Contractors are required to establish separate billing accounts with each using agency and invoice them directly. Each invoice shall be itemized with adequate detail and match the line item on the Purchase Order. In no instance shall any payment be made for services to the Contractor that are not in accordance with the prices on the Purchase Order, the Contract, updated price lists or any discounts negotiated by the purchasing agency.

V.22 CONTRACT-015.3 Invoice Requirement – SAP Purchase Orders (Feb 2007)

Unless otherwise specified or unless the Contractor has been authorized by the Commonwealth for Electronic Invoicing, Evaluated Receipt Settlement or Vendor Self-Invoicing, the Contractor shall send an invoice itemized by purchase order line item to the address referenced on the Purchase Order promptly after the item(s) are delivered. The invoice should include only amounts due under the Purchase Order. The Purchase Order number must be included on all invoices. In addition, the Commonwealth shall have the right to require the Contractor to prepare and submit a "Work In Progress" sheet that contains, at a minimum, the tasks performed, number of hours, hourly rates and the Purchase Order or task order to which it refers.

V.23 CONTRACT-016.1 Payment (Oct 2006)

- a. The Commonwealth shall put forth reasonable efforts to make payment by the required payment date. The required payment date is: (a) the date on which payment is due under the terms of the Contract; (b) thirty (30) days after a proper invoice actually is received at the "Bill To" address if a date on which payment is due is not specified in the Contract (a "proper" invoice is not received until the Commonwealth accepts the service as satisfactorily performed); or (c) the payment date specified on the invoice if later than the dates established by (a) and (b) above. Payment may be delayed if the payment amount on an invoice is not based upon the price(s) as stated in the Contract. If any payment is not made within fifteen (15) days after the required payment date, the Commonwealth may pay interest as determined by the Secretary of Budget in accordance with Act No. 266 of 1982 and regulations promulgated pursuant thereto. Payment should not be construed by the Contractor as

acceptance of the service performed by the Contractor. The Commonwealth reserves the right to conduct further testing and inspection after payment, but within a reasonable time after performance, and to reject the service if such post payment testing or inspection discloses a defect or a failure to meet specifications. The Contractor agrees that the Commonwealth may set off the amount of any state tax liability or other obligation of the Contractor or its subsidiaries to the Commonwealth against any payments due the Contractor under any contract with the Commonwealth.

- b. The Commonwealth shall have the option of using the Commonwealth purchasing card to make purchases under the Contract or Purchase Order. The Commonwealth's purchasing card is similar to a credit card in that there will be a small fee which the Contractor will be required to pay and the Contractor will receive payment directly from the card issuer rather than the Commonwealth. Any and all fees related to this type of payment are the responsibility of the Contractor. In no case will the Commonwealth allow increases in prices to offset credit card fees paid by the Contractor or any other charges incurred by the Contractor, unless specifically stated in the terms of the Contract or Purchase Order.

V.24 CONTRACT-016.2 ACH Payments (Aug 2007)

- a. The Commonwealth will make contract payments through the Automated Clearing House (ACH). Within 10 days of award of the contract or purchase order, the contractor must submit or must have already submitted their ACH information within their user profile in the Commonwealth's procurement system (SRM).
- b. The contractor must submit a unique invoice number with each invoice submitted. The unique invoice number will be listed on the Commonwealth of Pennsylvania's ACH remittance advice to enable the contractor to properly apply the state agency's payment to the invoice submitted.
- c. It is the responsibility of the contractor to ensure that the ACH information contained in SRM is accurate and complete. Failure to maintain accurate and complete information may result in delays in payments.

V.25 CONTRACT-017.1 Taxes (Dec 5 2006)

The Commonwealth is exempt from all excise taxes imposed by the Internal Revenue Service and has accordingly registered with the Internal Revenue Service to make tax free purchases under Registration No. 23-23740001-K. With the exception of purchases of the following items, no exemption certificates are required and none will be issued: undyed diesel fuel, tires, trucks, gas guzzler emergency vehicles, and sports fishing equipment. The Commonwealth is also exempt from Pennsylvania state sales tax, local sales tax, public transportation assistance taxes and fees and vehicle rental tax. The Department of Revenue regulations provide that exemption certificates are not required for sales made to governmental entities and none will be issued. Nothing in this paragraph is meant to exempt a construction contractor from the payment of any of these taxes or fees which are required to be paid with respect to the purchase, use, rental, or lease of tangible personal property or taxable services used or transferred in connection with the performance of a construction contract.

V.26 CONTRACT-018.1 Assignment of Antitrust Claims (Oct 2006)

The Contractor and the Commonwealth recognize that in actual economic practice, overcharges by the Contractor's suppliers resulting from violations of state or federal antitrust laws are in fact borne by the Commonwealth. As part of the consideration for the award of the Contract, and intending to be legally bound, the Contractor assigns to the Commonwealth all right, title and interest in and to any claims the Contractor now has, or may acquire, under state or federal antitrust laws relating to the products and services which are the subject of this Contract.

V.27 CONTRACT-019.1 Hold Harmless Provision (Nov 30 2006)

- a. The Contractor shall hold the Commonwealth harmless from and indemnify the Commonwealth against any and all third party claims, demands and actions based upon or arising out of any activities performed by the Contractor and its employees and agents under this Contract, provided the Commonwealth gives Contractor prompt notice of any such claim of which it learns. Pursuant to the Commonwealth Attorneys Act (71 P.S. Section 732-101, et seq.), the Office of Attorney General (OAG) has the sole authority to represent the Commonwealth in actions brought against the Commonwealth. The OAG may, however, in its sole discretion and under such terms as it deems appropriate, delegate its right of defense. If OAG delegates the defense to the Contractor, the Commonwealth will cooperate with all reasonable requests of Contractor made in the defense of such suits.
- b. Notwithstanding the above, neither party shall enter into any settlement without the other party's written consent, which shall not be unreasonably withheld. The Commonwealth may, in its sole discretion, allow the Contractor to control the defense and any related settlement negotiations.

V.28 CONTRACT-020.1 Audit Provisions (Oct 2006)

The Commonwealth shall have the right, at reasonable times and at a site designated by the Commonwealth, to audit the books, documents and records of the Contractor to the extent that the books, documents and records relate to costs or pricing data for the Contract. The Contractor agrees to maintain records which will support the prices charged and costs incurred for the Contract. The Contractor shall preserve books, documents, and records that relate to costs or pricing data for the Contract for a period of three (3) years from date of final payment. The Contractor shall give full and free access to all records to the Commonwealth and/or their authorized representatives.

V.29 CONTRACT-021.1 Default (Dec 12 2006)

- a. The Commonwealth may, subject to the Force Majeure provisions of this Contract, and in addition to its other rights under the Contract, declare the Contractor in default by written notice thereof to the Contractor, and terminate (as provided in the Termination Provisions of this Contract) the whole or any part of this Contract or any Purchase Order for any of the following reasons:
 - 1) Failure to begin work within the time specified in the Contract or Purchase Order or as otherwise specified;
 - 2) Failure to perform the work with sufficient labor, equipment, or material to insure the completion of the specified work in accordance with the Contract or Purchase Order terms;
 - 3) Unsatisfactory performance of the work;
 - 4) Failure to deliver the awarded item(s) within the time specified in the Contract or Purchase Order or as otherwise specified;
 - 5) Improper delivery;
 - 6) Failure to provide an item(s) which is in conformance with the specifications referenced in the Contract or Purchase Order;
 - 7) Delivery of a defective item;

- 8) Failure or refusal to remove material, or remove and replace any work rejected as defective or unsatisfactory;
 - 9) Discontinuance of work without approval;
 - 10) Failure to resume work, which has been discontinued, within a reasonable time after notice to do so;
 - 11) Insolvency or bankruptcy;
 - 12) Assignment made for the benefit of creditors;
 - 13) Failure or refusal within 10 days after written notice by the Contracting Officer, to make payment or show cause why payment should not be made, of any amounts due for materials furnished, labor supplied or performed, for equipment rentals, or for utility services rendered;
 - 14) Failure to protect, to repair, or to make good any damage or injury to property;
 - 15) Breach of any provision of the Contract;
 - 16) Failure to comply with representations made in the Contractor's bid/proposal; or
 - 17) Failure to comply with applicable industry standards, customs, and practice.
- b. In the event that the Commonwealth terminates this Contract or any Purchase Order in whole or in part as provided in Subparagraph a. above, the Commonwealth may procure, upon such terms and in such manner as it determines, items similar or identical to those so terminated, and the Contractor shall be liable to the Commonwealth for any reasonable excess costs for such similar or identical items included within the terminated part of the Contract or Purchase Order.
- c. If the Contract or a Purchase Order is terminated as provided in Subparagraph a. above, the Commonwealth, in addition to any other rights provided in this paragraph, may require the Contractor to transfer title and deliver immediately to the Commonwealth in the manner and to the extent directed by the Contracting Officer, such partially completed items, including, where applicable, reports, working papers and other documentation, as the Contractor has specifically produced or specifically acquired for the performance of such part of the Contract or Purchase Order as has been terminated. Except as provided below, payment for completed work accepted by the Commonwealth shall be at the Contract price. Except as provided below, payment for partially completed items including, where applicable, reports and working papers, delivered to and accepted by the Commonwealth shall be in an amount agreed upon by the Contractor and Contracting Officer. The Commonwealth may withhold from amounts otherwise due the Contractor for such completed or partially completed works, such sum as the Contracting Officer determines to be necessary to protect the Commonwealth against loss.
- d. The rights and remedies of the Commonwealth provided in this paragraph shall not be exclusive and are in addition to any other rights and remedies provided by law or under this Contract.
- e. The Commonwealth's failure to exercise any rights or remedies provided in this paragraph shall not be construed to be a waiver by the Commonwealth of its rights and remedies in regard to the event of default or any succeeding event of default.

- f. Following exhaustion of the Contractor's administrative remedies as set forth in the Contract Controversies Provision of the Contract, the Contractor's exclusive remedy shall be to seek damages in the Board of Claims.

V.30 CONTRACT-022.1 Force Majeure (Oct 2006)

Neither party will incur any liability to the other if its performance of any obligation under this Contract is prevented or delayed by causes beyond its control and without the fault or negligence of either party. Causes beyond a party's control may include, but aren't limited to, acts of God or war, changes in controlling law, regulations, orders or the requirements of any governmental entity, severe weather conditions, civil disorders, natural disasters, fire, epidemics and quarantines, general strikes throughout the trade, and freight embargoes.

The Contractor shall notify the Commonwealth orally within five (5) days and in writing within ten (10) days of the date on which the Contractor becomes aware, or should have reasonably become aware, that such cause would prevent or delay its performance. Such notification shall (i) describe fully such cause(s) and its effect on performance, (ii) state whether performance under the contract is prevented or delayed and (iii) if performance is delayed, state a reasonable estimate of the duration of the delay. The Contractor shall have the burden of proving that such cause(s) delayed or prevented its performance despite its diligent efforts to perform and shall produce such supporting documentation as the Commonwealth may reasonably request. After receipt of such notification, the Commonwealth may elect to cancel the Contract, cancel the Purchase Order, or to extend the time for performance as reasonably necessary to compensate for the Contractor's delay.

In the event of a declared emergency by competent governmental authorities, the Commonwealth by notice to the Contractor, may suspend all or a portion of the Contract or Purchase Order.

V.31 CONTRACT-023.1a Termination Provisions (Oct 2006)

The Commonwealth has the right to terminate this Contract or any Purchase Order for any of the following reasons. Termination shall be effective upon written notice to the Contractor.

- a. **TERMINATION FOR CONVENIENCE:** The Commonwealth shall have the right to terminate the Contract or a Purchase Order for its convenience if the Commonwealth determines termination to be in its best interest. The Contractor shall be paid for work satisfactorily completed prior to the effective date of the termination, but in no event shall the Contractor be entitled to recover loss of profits.
- b. **NON-APPROPRIATION:** The Commonwealth's obligation to make payments during any Commonwealth fiscal year succeeding the current fiscal year shall be subject to availability and appropriation of funds. When funds (state and/or federal) are not appropriated or otherwise made available to support continuation of performance in a subsequent fiscal year period, the Commonwealth shall have the right to terminate the Contract or a Purchase Order. The Contractor shall be reimbursed for the reasonable value of any nonrecurring costs incurred but not amortized in the price of the supplies or services delivered under the Contract. Such reimbursement shall not include loss of profit, loss of use of money, or administrative or overhead costs. The reimbursement amount may be paid for any appropriations available for that purpose
- c. **TERMINATION FOR CAUSE:** The Commonwealth shall have the right to terminate the Contract or a Purchase Order for Contractor default under Default Clause upon written notice to the Contractor. The Commonwealth shall also have the right, upon written notice to the Contractor, to terminate the Contract or a Purchase Order for other cause as specified in the Contract or by law. If it is later determined that the Commonwealth erred in terminating the Contract or a Purchase Order for cause, then, at the Commonwealth's discretion, the Contract or Purchase Order shall be deemed to have been terminated for convenience under the Subparagraph a.

V.32 CONTRACT-024.1 Contract Controversies (Oct 2006)

- a. In the event of a controversy or claim arising from the Contract, the Contractor must, within six months after the cause of action accrues, file a written claim with the contracting officer for a determination. The claim shall state all grounds upon which the Contractor asserts a controversy exists. If the Contractor fails to file a claim or files an untimely claim, the Contractor is deemed to have waived its right to assert a claim in any forum.
- b. The contracting officer shall review timely-filed claims and issue a final determination, in writing, regarding the claim. The final determination shall be issued within 120 days of the receipt of the claim, unless extended by consent of the contracting officer and the Contractor. The contracting officer shall send his/her written determination to the Contractor. If the contracting officer fails to issue a final determination within the 120 days (unless extended by consent of the parties), the claim shall be deemed denied. The contracting officer's determination shall be the final order of the purchasing agency.
- c. Within fifteen (15) days of the mailing date of the determination denying a claim or within 135 days of filing a claim if, no extension is agreed to by the parties, whichever occurs first, the Contractor may file a statement of claim with the Commonwealth Board of Claims. Pending a final judicial resolution of a controversy or claim, the Contractor shall proceed diligently with the performance of the Contract in a manner consistent with the determination of the contracting officer and the Commonwealth shall compensate the Contractor pursuant to the terms of the Contract.

V.33 CONTRACT-025.1 Assignability and Subcontracting (Oct 2006)

- a. Subject to the terms and conditions of this paragraph, this Contract shall be binding upon the parties and their respective successors and assigns.
- b. The Contractor shall not subcontract with any person or entity to perform all or any part of the work to be performed under this Contract without the prior written consent of the Contracting Officer, which consent may be withheld at the sole and absolute discretion of the Contracting Officer.
- c. The Contractor may not assign, in whole or in part, this Contract or its rights, duties, obligations, or responsibilities hereunder without the prior written consent of the Contracting Officer, which consent may be withheld at the sole and absolute discretion of the Contracting Officer.
- d. Notwithstanding the foregoing, the Contractor may, without the consent of the Contracting Officer, assign its rights to payment to be received under the Contract, provided that the Contractor provides written notice of such assignment to the Contracting Officer together with a written acknowledgement from the assignee that any such payments are subject to all of the terms and conditions of this Contract.
- e. For the purposes of this Contract, the term "assign" shall include, but shall not be limited to, the sale, gift, assignment, pledge, or other transfer of any ownership interest in the Contractor provided, however, that the term shall not apply to the sale or other transfer of stock of a publicly traded company.
- f. Any assignment consented to by the Contracting Officer shall be evidenced by a written assignment agreement executed by the Contractor and its assignee in which the assignee agrees to be legally bound by all of the terms and conditions of the Contract and to assume the duties, obligations, and responsibilities being assigned.

- g. A change of name by the Contractor, following which the Contractor's federal identification number remains unchanged, shall not be considered to be an assignment hereunder. The Contractor shall give the Contracting Officer written notice of any such change of name.

V.34 CONTRACT-026.1 Other Contractors (Oct 2006)

The Commonwealth may undertake or award other contracts for additional or related work, and the Contractor shall fully cooperate with other contractors and Commonwealth employees, and coordinate its work with such additional work as may be required. The Contractor shall not commit or permit any act that will interfere with the performance of work by any other contractor or by Commonwealth employees. This paragraph shall be included in the Contracts of all contractors with which this Contractor will be required to cooperate. The Commonwealth shall equitably enforce this paragraph as to all contractors to prevent the imposition of unreasonable burdens on any contractor.

V.35 CONTRACT-027.1 Nondiscrimination/Sexual Harassment Clause (Oct 2006)

During the term of the Contract, the Contractor agrees as follows:

- a. In the hiring of any employees for the manufacture of supplies, performance of work, or any other activity required under the Contract or any subcontract, the Contractor, subcontractor or any person acting on behalf of the Contractor or subcontractor shall not by reason of gender, race, creed, or color discriminate against any citizen of this Commonwealth who is qualified and available to perform the work to which the employment relates.
- b. Neither the Contractor nor any subcontractor nor any person on their behalf shall in any manner discriminate against or intimidate any employee involved in the manufacture of supplies, the performance of work or any other activity required under the Contract on account of gender, race, creed, or color.
- c. The Contractor and any subcontractors shall establish and maintain a written sexual harassment policy and shall inform their employees of the policy. The policy must contain a notice that sexual harassment will not be tolerated and employees who practice it will be disciplined.
- d. The Contractor shall not discriminate by reason of gender, race, creed, or color against any subcontractor or supplier who is qualified to perform the work to which the contract relates.
- e. The Contractor and each subcontractor shall furnish all necessary employment documents and records to and permit access to its books, records, and accounts by the contracting officer and the Department of General Services' Bureau of Contract Administration and Business Development for purposes of investigation to ascertain compliance with the provisions of this Nondiscrimination/Sexual Harassment Clause. If the Contractor or any subcontractor does not possess documents or records reflecting the necessary information requested, it shall furnish such information on reporting forms supplied by the contracting officer or the Bureau of Contract Administration and Business Development.
- f. The Contractor shall include the provisions of this Nondiscrimination/Sexual Harassment Clause in every subcontract so that such provisions will be binding upon each subcontractor.
- g. The Commonwealth may cancel or terminate the Contract, and all money due or to become due under the

Contract may be forfeited for a violation of the terms and conditions of this Nondiscrimination/Sexual Harassment Clause. In addition, the agency may proceed with debarment or suspension and may place the Contractor in the Contractor Responsibility File.

V.36 CONTRACT-028.1 Contractor Integrity Provisions (Oct 2006)

- a. For purposes of this clause only, the words "confidential information," "consent," "contractor," "financial interest," and "gratuity" shall have the following definitions.
- 1) **Confidential information** means information that is not public knowledge, or available to the public on request, disclosure of which would give an unfair, unethical, or illegal advantage to another desiring to contract with the Commonwealth.
 - 2) **Consent** means written permission signed by a duly authorized officer or employee of the Commonwealth, provided that where the material facts have been disclosed, in writing, by prequalification, bid, proposal, or contractual terms, the Commonwealth shall be deemed to have consented by virtue of execution of this agreement.
 - 3) **Contractor** means the individual or entity that has entered into the Contract with the Commonwealth, including directors, officers, partners, managers, key employees and owners of more than a five percent interest.
 - 4) **Financial interest** means:
 - a) Ownership of more than a five percent interest in any business; or
 - b) Holding a position as an officer, director, trustee, partner, employee, or the like, or holding any position of management.
 - 5) **Gratuity** means any payment of more than nominal monetary value in the form of cash, travel, entertainment, gifts, meals, lodging, loans, subscriptions, advances, deposits of money, services, employment, or contracts of any kind.
- b. The Contractor shall maintain the highest standards of integrity in the performance of the Contract and shall take no action in violation of state or federal laws, regulations, or other requirements that govern contracting with the Commonwealth.
- c. The Contractor shall not disclose to others any confidential information gained by virtue of the Contract.
- d. The Contractor shall not, in connection with this or any other agreement with the Commonwealth, directly, or indirectly, offer, confer, or agree to confer any pecuniary benefit on anyone as consideration for the decision, opinion, recommendation, vote, other exercise of discretion, or violation of a known legal duty by any officer or employee of the Commonwealth.
- e. The Contractor shall not, in connection with this or any other agreement with the Commonwealth, directly or indirectly, offer, give, or agree or promise to give to anyone any gratuity for the benefit of or at the direction or request of any officer or employee of the Commonwealth.

- f. Except with the consent of the Commonwealth, neither the Contractor nor anyone in privity with him or her shall accept or agree to accept from, or give or agree to give to, any person, any gratuity from any person in connection with the performance of work under the Contract except as provided therein.
- g. Except with the consent of the Commonwealth, the Contractor shall not have a financial interest in any other contractor, subcontractor, or supplier providing services, labor, or material on this project.
- h. The Contractor, upon being informed that any violation of these provisions has occurred or may occur, shall immediately notify the Commonwealth in writing.
- i. The Contractor, by execution of the Contract and by the submission of any bills or invoices for payment pursuant thereto, certifies, and represents that he or she has not violated any of these provisions.
- j. The Contractor, upon the inquiry or request of the Inspector General of the Commonwealth or any of that official's agents or representatives, shall provide, or if appropriate, make promptly available for inspection or copying, any information of any type or form deemed relevant by the Inspector General to the Contractor's integrity or responsibility, as those terms are defined by the Commonwealth's statutes, regulations, or management directives. Such information may include, but shall not be limited to, the Contractor's business or financial records, documents or files of any type or form which refers to or concern the Contract. Such information shall be retained by the Contractor for a period of three years beyond the termination of the Contract unless otherwise provided by law.
- k. For violation of any of the above provisions, the Commonwealth may terminate this and any other agreement with the Contractor, claim liquidated damages in an amount equal to the value of anything received in breach of these provisions, claim damages for all expenses incurred in obtaining another Contractor to complete performance hereunder, and debar and suspend the Contractor from doing business with the Commonwealth. These rights and remedies are cumulative, and the use or nonuse of any one shall not preclude the use of all or any other. These rights and remedies are in addition to those the Commonwealth may have under law, statute, regulation, or otherwise.

V.37 CONTRACT-029.1 Contractor Responsibility Provisions (Oct 2006)

- a. The Contractor certifies, for itself and all its subcontractors, that as of the date of its execution of this Bid/Contract, that neither the Contractor, nor any subcontractors, nor any suppliers are under suspension or debarment by the Commonwealth or any governmental entity, instrumentality, or authority and, if the Contractor cannot so certify, then it agrees to submit, along with its Bid, a written explanation of why such certification cannot be made.
- b. The Contractor also certifies, that as of the date of its execution of this Bid/Contract, it has no tax liabilities or other Commonwealth obligations.
- c. The Contractor's obligations pursuant to these provisions are ongoing from and after the effective date of the contract through the termination date thereof. Accordingly, the Contractor shall have an obligation to inform the Commonwealth if, at any time during the term of the Contract, it becomes delinquent in the payment of taxes, or other Commonwealth obligations, or if it or any of its subcontractors are suspended or debarred by the Commonwealth, the federal government, or any other state or governmental entity. Such notification shall be made within 15 days of the date of suspension or debarment.

- d. The failure of the Contractor to notify the Commonwealth of its suspension or debarment by the Commonwealth, any other state, or the federal government shall constitute an event of default of the Contract with the Commonwealth.
- e. The Contractor agrees to reimburse the Commonwealth for the reasonable costs of investigation incurred by the Office of State Inspector General for investigations of the Contractor's compliance with the terms of this or any other agreement between the Contractor and the Commonwealth, which results in the suspension or debarment of the Contractor. Such costs shall include, but shall not be limited to, salaries of investigators, including overtime; travel and lodging expenses; and expert witness and documentary fees. The Contractor shall not be responsible for investigative costs for investigations that do not result in the Contractor's suspension or debarment.
- f. The Contractor may obtain a current list of suspended and debarred Commonwealth contractors by either searching the internet at <http://www.dgs.state.pa.us/> or contacting the:

Department of General Services
Office of Chief Counsel
603 North Office Building
Harrisburg, PA 17125
Telephone No. (717) 783-6472
FAX No. (717) 787-9138

V.38 CONTRACT-030.1 Americans with Disabilities Act (Oct 2006)

- a. Pursuant to federal regulations promulgated under the authority of The Americans With Disabilities Act, 28 C.F.R. Section 35.101 et seq., the Contractor understands and agrees that it shall not cause any individual with a disability to be excluded from participation in this Contract or from activities provided for under this Contract on the basis of the disability. As a condition of accepting this contract, the Contractor agrees to comply with the "General Prohibitions Against Discrimination," 28 C.F.R. Section 35.130, and all other regulations promulgated under Title II of The Americans With Disabilities Act which are applicable to all benefits, services, programs, and activities provided by the Commonwealth of Pennsylvania through contracts with outside contractors.
- b. The Contractor shall be responsible for and agrees to indemnify and hold harmless the Commonwealth of Pennsylvania from all losses, damages, expenses, claims, demands, suits, and actions brought by any party against the Commonwealth of Pennsylvania as a result of the Contractor's failure to comply with the provisions of Subparagraph a. above.

V.39 CONTRACT-031.1 Hazardous Substances (Oct 2006)

The Contractor shall provide information to the Commonwealth about the identity and hazards of hazardous substances supplied or used by the Contractor in the performance of the Contract. The Contractor must comply with Act 159 of October 5, 1984, known as the "Worker and Community Right to Know Act" (the "Act") and the regulations promulgated pursuant thereto at 4 Pa. Code Section 301.1 et seq.

- a. Labeling. The Contractor shall insure that each individual product (as well as the carton, container or package in which the product is shipped) of any of the following substances (as defined by the Act and the regulations) supplied by the Contractor is clearly labeled, tagged or marked with the information listed in Subparagraphs (1)

through (4):

1) Hazardous substances:

- a) The chemical name or common name,
- b) A hazard warning, and
- c) The name, address, and telephone number of the manufacturer.

2) Hazardous mixtures:

- a) The common name, but if none exists, then the trade name,
- b) The chemical or common name of special hazardous substances comprising .01% or more of the mixture,
- c) The chemical or common name of hazardous substances consisting 1.0% or more of the mixture,
- d) A hazard warning, and
- e) The name, address, and telephone number of the manufacturer.

3) Single chemicals:

- a) The chemical name or the common name,
- b) A hazard warning, if appropriate, and
- c) The name, address, and telephone number of the manufacturer.

4) Chemical Mixtures:

- a) The common name, but if none exists, then the trade name,
- b) A hazard warning, if appropriate,
- c) The name, address, and telephone number of the manufacturer, and
- d) The chemical name or common name of either the top five substances by volume or those substances consisting of 5.0% or more of the mixture.

A common name or trade name may be used only if the use of the name more easily or readily identifies the true nature of the hazardous substance, hazardous mixture, single chemical, or mixture involved.

Container labels shall provide a warning as to the specific nature of the hazard arising from the substance in the container.

The hazard warning shall be given in conformity with one of the nationally recognized and accepted systems of providing warnings, and hazard warnings shall be consistent with one or more of the recognized systems throughout the workplace. Examples are:

NFPA 704, Identification of the Fire Hazards of Materials.

National Paint and Coatings Association: Hazardous Materials Identification System.

American Society for Testing and Materials, Safety Alert Pictorial Chart.

American National Standard Institute, Inc., for the Precautionary Labeling of Hazardous Industrial Chemicals.

Labels must be legible and prominently affixed to and displayed on the product and the carton, container, or package so that employees can easily identify the substance or mixture present therein.

- b. Material Safety Data Sheet. The contractor shall provide Material Safety Data Sheets (MSDS) with the information required by the Act and the regulations for each hazardous substance or hazardous mixture. The Commonwealth must be provided an appropriate MSDS with the initial shipment and with the first shipment after an MSDS is updated or product changed. For any other chemical, the contractor shall provide an appropriate MSDS, if the manufacturer, importer, or supplier produces or possesses the MSDS. The contractor shall also notify the Commonwealth when a substance or mixture is subject to the provisions of the Act. Material Safety Data Sheets may be attached to the carton, container, or package mailed to the Commonwealth at the time of shipment.

V.40 CONTRACT-032.1 Covenant Against Contingent Fees (Oct 2006)

The Contractor warrants that no person or selling agency has been employed or retained to solicit or secure the Contract upon an agreement or understanding for a commission, percentage, brokerage, or contingent fee, except bona fide employees or bona fide established commercial or selling agencies maintained by the Contractor for the purpose of securing business. For breach or violation of this warranty, the Commonwealth shall have the right to terminate the Contract without liability or in its discretion to deduct from the Contract price or consideration, or otherwise recover the full amount of such commission, percentage, brokerage, or contingent fee.

V.41 CONTRACT-033.1 Applicable Law (Oct 2006)

This Contract shall be governed by and interpreted and enforced in accordance with the laws of the Commonwealth of Pennsylvania (without regard to any conflict of laws provisions) and the decisions of the Pennsylvania courts. The Contractor consents to the jurisdiction of any court of the Commonwealth of Pennsylvania and any federal courts in Pennsylvania, waiving any claim or defense that such forum is not convenient or proper. The Contractor agrees that any such court shall have in personam jurisdiction over it, and consents to service of process in any manner authorized by Pennsylvania law.

V.42 CONTRACT- 034.1b Integration (Nov 30 2006)

This Contract, including the Invitation for Bids, the Contractor's bid, all referenced documents, and any Purchase Order constitutes the entire agreement between the parties. No agent, representative, employee or officer of either the Commonwealth or the Contractor has authority to make, or has made, any statement, agreement or representation, oral or written, in connection with the Contract, which in any way can be deemed to modify, add to or detract from, or otherwise change or alter its terms and conditions. No negotiations between the parties, nor any custom or usage, shall be permitted to modify or contradict any of the terms and conditions of the Contract. No modifications, alterations, changes, or waiver to the Contract or any of its terms shall be valid or binding unless accomplished by a written amendment signed by both parties.

V.43 CONTRACT-034.2b Order of Precedence - IFB (Dec 6 2006)

In the event there is a conflict among the documents comprising this Contract, the Commonwealth and the Contractor agree on the following order of precedence: the Contract; the IFB; and the Contractor's Bid in Response to the IFB.

V.44 CONTRACT-035.1a Changes (Oct 2006)

The Commonwealth reserves the right to make changes at any time during the term of the Contract or any renewals or extensions thereof: 1) to increase or decrease the quantities resulting from variations between any estimated quantities in the Contract and actual quantities; 2) to make changes to the services within the scope of the Contract; 3) to notify the Contractor that the Commonwealth is exercising any Contract renewal or extension option; or 4) to modify the time of performance that does not alter the scope of the Contract to extend the completion date beyond the Expiration Date of the Contract or any renewals or extensions thereof. Any such change shall be made by the Contracting Officer by notifying the Contractor in writing. The change shall be effective as of the date of the change, unless the notification of change specifies a later effective date. Such increases, decreases, changes, or modifications will not invalidate the Contract, nor, if performance security is being furnished in conjunction with the Contract, release the security obligation. The Contractor agrees to provide the service in accordance with the change order. Any dispute by the Contractor in regard to the performance required by any notification of change shall be handled through Contract Controversies Provision.

V.45 CONTRACT-037.1b Confidentiality (Oct 2006)

The Contractor agrees to protect the confidentiality of the Commonwealth's information. The Commonwealth agrees to protect the confidentiality of Contractor's confidential information. In order for information to be deemed to be confidential, the party claiming confidentiality must designate the information as "confidential" in such a way as to give notice to the other party. The parties agree that such confidential information shall not be copied, in whole or in part, except when essential for authorized use under this Contract. Each copy of such confidential information shall be marked by the party making the copy with all notices appearing in the original. Upon termination or cancellation of this Contract or any license granted hereunder, the receiving party will return to the disclosing party all copies of the confidential information in the receiving party's possession, other than one copy, which may be maintained for archival purposes only. Both parties agree that a material breach of these requirements may, after failure to cure within the time frame specified in this Contract, and at the discretion of the non-breaching party, result in termination for default.

The obligations stated in this Section do not apply to information:

- i. already known to the recipient at the time of disclosure;

- ii. independently generated by the recipient and not derived from the information supplied by the disclosing party;
- iii. known or available to the public, except where such knowledge or availability is the result of unauthorized disclosure by the recipient of the proprietary information;
- iv. disclosed to the recipient without a similar restriction by a third party who has the right to make such disclosure; or
- v. required to be disclosed by the recipient by law, regulation, court order, or other legal process.

V.46 CONTRACT-040.1b Liquidated Damages - Vehicles (Dec 6 2006)

If any item is not delivered within the contract specified time limits, the delay will interfere with the proper implementation of the Commonwealth's programs and utilizing the item, to the loss and damage of the Commonwealth. From the nature of the case it would be impractical and extremely difficult to fix the actual damage sustained in the event of any such action. The Commonwealth and the Contractor, therefore, presume that in the event of any such delay the amount of damage which will be sustained from a delay will be \$ 20.00 per day per vehicle, and they agree that in the event of any such delay, the Contractor shall pay such amount as liquidated damages and not as a penalty. The Commonwealth, at its option, for amounts due the Commonwealth as liquidated damages, may deduct such from any money payable to the Contractor or may bill the Contractor as a separate item. The Commonwealth shall notify the Contractor in writing of any claims for liquidated damages pursuant to this paragraph before the date the Commonwealth deducts such sums from money payable to the Contractor. Delivery of an item, which is rejected by the Commonwealth, shall not toll the running of the days for purposes of determining the amount of liquidated damages.

V.47 CONTRACT-046.1 Manufacturer's Price Reduction (Oct 2006)

If, prior to the delivery of the awarded item(s) by the Contractor, a price reduction is announced by the original equipment manufacturer, a comparative price reduction will be given to the Commonwealth by the Contractor.

V.48 CONTRACT-047.1 Motor Vehicles to be manufactured in North America (Oct 2006)

All motor vehicles furnished by the Contractor pursuant to the Contract must be manufactured in North America. North America is defined as the United States, Canada, and Mexico. A motor vehicle is manufactured in North America if a substantial majority of the principal components are assembled into the final products in an assembly plant in North America. The Contractor shall be prepared to prove that the motor vehicles that will be, or have been, furnished to the Commonwealth will be or are, in fact, manufactured in North America in accordance with Sections 3731-3736 of the Commonwealth Procurement Code (62 Pa. C.S. Sections 3731-3736), known as the Motor Vehicle Procurement Act. No payment shall be made to the Contractor unless the Commonwealth is satisfied that the Contractor has complied with these provisions and the Motor Vehicle Procurement Act. Any payments made to the Contractor, which should not have been made, shall be recoverable directly from the Contractor. In addition to the withholding of payments, any person who willfully violates any of the provisions of the Motor Vehicle Procurement Act may be prohibited by any public agency from participation in Contracts awarded by the public agency for a period of five years from the date of determination that a violation has occurred.

V.49 CONTRACT-047.2a General Requirements PennDOT Vehicles/Equipment (March 5, 2007)

These General Requirements shall apply to all on-road and off-road vehicles, highway equipment, agricultural equipment and construction equipment, procured for use by the Department of Transportation, Commonwealth of Pennsylvania (PennDOT). These requirements are in addition to any supplemental specifications identified in the invitation for bids. The following shall be considered MINIMUM requirements.

A. STANDARDS, CODES, RULES, REGULATIONS:

1. Each vehicle or unit of equipment shall conform to any and all requirements contained in the Pennsylvania Motor Vehicle Code.
2. Each vehicle or unit of equipment shall comply with all current applicable Federal Motor Vehicle Safety Standards, Federal and Pennsylvania Exhaust Emission and Noise Standards, and EPA and OSHA requirements. The appropriate decals indicating compliance shall be affixed to the vehicle/equipment.
3. Each vehicle or unit of equipment shall be manufactured in accordance with any codes, standards and engineering practices as recommended by the following professional organizations for the specific vehicle/equipment:

American Institute of Steel Construction (AISC)
American National Standards Institute (ANSI)
American Society of Mechanical Engineers (ASME)
American Society for Testing and Materials (ASTM)
American Trucking Association (ATA)
American Welding Society (AWS)
American Wood-Preservers Association (AWPA)
Battery Council International (BCI)
British Standards Institute (BSI): Limits and Fits
Compressed Air and Gas Institute (CAGI)
Industrial Fastener Institute (IFI)
International Standards Organization (ISO)
Joint Industrial Council (JIC)
National Fire Protection Association (NFPA)
National Truck and Equipment Association (NTEA)
Power Crane and Shovel Association (PSCA)
Society of Automotive Engineers (SAE)
Society of Manufacturing Engineers (SME)
Steel Structure Painting Council (SSPC)
Tire and Rim Association (TRA)

B. COMPONENTS, PARTS AND ACCESSORIES:

1. When "No Substitute" components, parts or accessories are designated, only this type of component, part or accessory is acceptable.

2. All equipment and parts furnished shall be of the manufacturer's most current design, shall be included in its most current published list of models in stock and shall satisfy, these specifications.
3. The same model components shall be utilized on all units supplied by the successful bidder under the specifications.
4. All electronic systems associated with the vehicle/equipment shall be properly insulated so as not to not cause any interference with the operation of the vehicle or the land mobile radio communications system, when properly installed in the vehicle.
5. Power systems must be compatible with the engine, transmission, axles, hydraulic system and power steering, etc., in order to meet the requirements specified herein.
6. Vehicles shall meet the maximum gradeability of the manufacturer when loaded to maximum Gross Vehicle Weight Rating ("GVWR") without exceeding the engine manufacturer's recommended maximum revolutions per minute ("RPM") based on maximum net torque.
7. The ratio of the rear axle and transmission shall be geared to maintain a road speed of approximately 65 mph on a level road, when operating at maximum GVWR without exceeding the recommended engine rpm figure. This is not applicable to construction type equipment.

C. SITE VISITS:

Prior to submission of its bid, a bidder may contact PennDOT and schedule a site visit to inspect vehicles/equipment (as available) in PennDOT's current inventory in order to further clarify any drawings, pictures and specifications. Units may be available in the field for bidders to inspect at one or more of PennDOT's Maintenance Districts, but the Commonwealth makes no guarantee that any particular vehicle/equipment shall be located at a site convenient to the bidder's place of business. The site visit must be scheduled with the Equipment Division by calling (717) 787-1567. It is the bidder's responsibility to complete the site visit in time to submit a bid. All travel will be at the bidder's expense.

D. ON BOARD VEHICLE/EQUIPMENT REQUIREMENTS:

1. Each vehicle and unit of equipment shall include the proper forms to apply for a Pennsylvania title and license. These forms will include: the original manufacturer's statement of origin signed by the successful bidder and notarized. All title papers shall be properly prepared and executed. The application for title, Form MV-1 shall indicate the name and address exactly as follows: Pa. Dept. of Transportation, Equipment Division, 17th Street and Arsenal Blvd., Harrisburg, PA 17120 (ATTN: Specifications Unit).
2. Trucks and trailers shall be certified to meet or exceed requirements to obtain a Pennsylvania license. For medium and heavy-duty trucks and vans, the GVWR shall be identified in the vehicle's cab as the final complete certification label (minimum rating). The Gross Combined Weight Rating (GCWR) shall be identified by decal in the cab to indicate the approved weight, which can be towed, if applicable.
3. Vehicles designated for on-road use shall meet the following requirements:
 - a. Shall have a valid Pennsylvania state inspection sticker.

- b. Shall have completed the manufacturers' recommended pre-delivery service.
- c. Shall have the vehicle manufacturer's model name and model number stated on a decal affixed to the inside of the driver's side door.
- d. Shall be clean, lubricated, serviced, gas tank filled to full recommended capacity, all adjustments completed, all mechanical and electrical motors and components fully functional and operational, and the vehicle will be "road ready" for immediate use.
- e. Shall have appropriately placed decals indicating the types of required fuels or lubricants and the capacity of each fluid's reservoir that is required by the vehicle.
- f. Shall have permanent antifreeze in each vehicle to protect it at a level of -35 F. Only a low silicate type anti-freeze will be used for vehicles having diesel engines.
- g. Shall be free from all dealer signs/emblems.
- h. Shall have all required rust proofing applied to the exterior and underside of the vehicle. No rustproofing compound can be on the personnel compartment's items or the exterior of the body in unsightly or unintended areas.
- i. Shall include a copy of the manufacturer's warranty and service policy with all warranty vouchers, certificates and coupons.
- j. Shall have each vehicle and major component identified with a metal identification tag that provides the OEM's name, model number and individual serial number. Tags will be affixed in an accessible and readable position on the item.

The above items are pre-delivery service items, and bidders should not misconstrue these requirements with warranty problems that arise after the Commonwealth accepts the completed unit which complies with the written specifications.

All charges for any of the aforementioned administrative and technical services and equipment are considered minimum acceptable requirements for delivery and shall be included in the bid price.

E. GENERAL WARRANTY REQUIREMENTS

The following warranty requirements are considered minimum unless otherwise stated in the invitation for bids. If the manufacturer's standard warranty exceeds the specified warranty, the manufacturer's standard warranty will apply. Manufacturer's warranty shall be provided in written or electronic form. All warranties will cover all labor and parts replacement during the warranty period, except as may be otherwise stated below or in the invitation for bids. This warranty, however, does not include items that must be replaced through ordinary wear and tear, but those parts ordinarily replaced through the servicing program will be replaced as part of the servicing program of equipment/vehicles, if appropriate. Parts replaced under this warranty will be of original equipment manufacturer (OEM) quality or higher. Service to the vehicle/equipment will be at a level to maintain or meet the manufacturer's requirements to sustain the warranty.

1. MEDIUM DUTY/HEAVY DUTY CAB & CHASSIS (19,501# GVWR or higher):

The chassis manufacturer's service and warranty program shall be for one (1) year or 12,000 miles (whichever first occurs).

2. LIGHT DUTY TRUCKS & VANS (up to 19,500# GVWR):

The chassis and cab manufacturer's service and warranty program shall be for three (3) years or 36,000 miles (whichever first occurs), including powertrain. A two (2) year, unlimited mileage warranty is acceptable in lieu of a three year, 36,000-mile warranty. The vehicle shall be certified as having a capacity of towing 1,000 pounds without voiding the warranty.

3. CONSTRUCTION EQUIPMENT: The construction and agricultural equipment manufacturer's service and warranty program shall be for a minimum of two (2) years or four thousand (4,000) hours whichever first occurs.

4. ADDITIONAL SPECIFIC WARRANTY ITEMS (Applies to light, medium and heavy duty trucks only)

a. RUST PROOFING WARRANTY

Cabs/cowls shall be warranted for five (5) full years with no mileage or hourly limitations. This will include rusting through or perforation from within. This warranty and service program covers both labor and parts for the full warranty period. Surface rust caused by chip, scratches, or damage caused by PennDOT employees is not covered by this warranty.

b. FRAME RAILS AND CROSSMEMBERS (Chassis)

For medium/heavy duty trucks, frame rails and cross members are warranted for five (5) full years with no mileage or hourly limitations. This warranty covers both parts and labor for the full warranty period. For light duty trucks and vans, the manufacturer's standard frame rail and crossmember warranty is acceptable.

c. FLAT BED WARRANTY

A vehicle's flat bed shall be warranted for three (3) years. This warranty covers both parts and labor for the full warranty period. A decal will be placed on the inside driver's door stating the warranty's terms and the name, address and telephone number of the contact person to initiate warranty claim services.

d. SERVICE/UTILITY BODY AND ASSOCIATED COMPONENTS WARRANTY

Fiberglass bodies will be warranted for five (5) years to include color fading. Steel service and utility bodies shall be warranted for five (5) years against defects and corrosion, including rust through or perforation from within. Surface rust caused by chip, scratches, or damage caused by PennDOT employees is not covered by this warranty. Associated components such as cranes, air compressors, and snowplows shall be covered by manufacturer's standard warranty. Manufacturer's standard warranty shall be provided in written or electronic form.

e. ENGINE AND TRANSMISSION WARRANTY

The engines for all Heavy/Medium Duty equipment/vehicles will be warranted for parts and labor for five (5) years or 150,000 miles (whichever first occurs). The engine warranty will include all items named or included within the valve covers, cylinder heads block, oil pan and injection pump. The transmission (automatic/manual) will be fully covered by the warranty and service program for two (2) years and will not be limited by mileage or hours. For light duty trucks and vans, the manufacturer's standard frame engine and transmission warranty is acceptable

f. WARRANTY CARD PROCEDURES

The successful bidder shall complete the warranty card except for the warranty start date. The PennDOT Equipment

Division shall inform the successful bidder of the following: model number of vehicle; serial number of vehicle, equipment number, and location assigned; date released to the counties.

F. PILOT MODEL:

PennDOT reserves the right to require the successful bidder to make mutually agreeable arrangements to deliver a "pilot model" for initial inspection. Pilot models(s) shall be delivered to the Department of Transportation, 17th St., & Arsenal Blvd., Harrisburg, PA 17120 for inspection, testing and approval. The remaining units shall not be delivered for inspection, testing and approval until after the pilot model has been accepted by PennDOT. The remaining units shall fully meet the requirements of the specifications and must be indistinguishable from the approved pilot model. Presentation of a pilot model will not be required if the quantity is only one (1) unit. The pilot model must meet all the mechanical requirements of the specifications. PennDOT may field test the equipment to determine if it meets the performance requirements of the specifications. Performance testing results will normally be completed within two (2) weeks of date of delivery. There are administrative items that are required to be presented at the pilot model inspection. It is imperative that all of these items be presented at this time so they are ready for shipment, when the balance of the units are delivered. PennDOT may withhold payment, where deemed necessary, pending receipt of these items. PennDOT disclaims any liability for damage to equipment that has not been unconditionally accepted by the PennDOT.

G. DELIVERY:

Time is of the essence. All units must be delivered within the number of days, specified in the invitation for bids, after receipt of the purchase order by the successful bidder. It shall be assumed by the parties that the successful bidder received the purchase order on the third business day following the date of the purchase order, unless the successful bidder provides credible evidence that the order was received on a later date. Bidders must specify delivery time in their bid. Phrases such as "as required", "as soon as possible", or "prompt" have no meaning and may be cause for rejection of the bid. The successful bidder shall deliver at ground level the complete unit(s) to the Equipment Division, 17th Street and Arsenal Blvd. Harrisburg, PA 17120. All deliveries shall be made on a working day between 7:00 AM and 3:30 PM. There is a loading dock at this location; however, any additional unloading cost shall be borne by the successful bidder. The terms of delivery are also controlled by other provisions in the invitation for bids.

The successful bidder shall submit to the PennDOT "on a continuing basis", all service bulletins and technical letters as regularly issued by a manufacturer to dealers or large fleets. All the relevant information shall be supplied for the unit(s) forwarded to the Commonwealth to inform PennDOT of any improvements, changes and/or problems concerning the unit and its component parts. This information shall be addressed to the Pennsylvania Department of Transportation, C/O Equipment Division, 17th St. & Arsenal Blvd., Harrisburg, PA 17120, ATTN: Chief, Equipment Division. PennDOT reserves the right to have its representative(s) periodically inspect each unit during assembly at the successful bidder's assembly point.

H. PROCEDURE FOR IMPLEMENTING REPAIRS:

In the event that a breakdown occurs, the repair work is to be performed by the successful bidder of record or his duly authorized representative within the Commonwealth. A copy of the successful bidder's work orders shall be supplied to the PennDOT County Equipment Manager and District Equipment Manager. Repairs assigned to the successful bidder can be performed at the successful bidder's place of business, at his duly authorized representative's place of business and, whenever possible, at the county maintenance facility or field locations. If services are to be performed at PennDOT's county maintenance facilities or in the field, the successful bidder must provide proof of insurance as stated in the contract attachments. County Equipment Managers shall notify the successful bidder or his duly authorized service representatives that the vehicle/equipment is down for component repairs and follow PennDOT standard procedure for handling warranty problems in accordance with the benefits of this warranty. At this time of notification, the location of repair is to be mutually agreed upon based on the most timely and cost effective basis to the Department. All work orders against the warranted repair shall be kept in PennDOT's Equipment History File at the county maintenance facility.

When repairs are to be performed at the successful bidder's place of business or his duly authorized representative's

place of business, transportation of the vehicle/equipment within the Commonwealth of Pennsylvania shall be made by PennDOT. If determined by PennDOT that repairs cannot be handled within the Commonwealth, then transportation to and from the Commonwealth of Pennsylvania shall be the responsibility of the successful bidder.

I. LUBRICATION AND COMPONENT INFORMATION:

The successful bidder shall provide lubrication and component information (as applicable) upon request by PennDOT. This information may be provided on PennDOT forms or may be presented on forms prepared by the successful bidder and/or manufacturer.

J. SUCCESSFUL BIDDER'S RIGHTS:

The successful bidder shall have the right to make periodic inspections to ascertain that the maintenance techniques and/or repair procedures are being administered in accordance with the guidelines set forth in this document. Preventive maintenance shall be performed by PennDOT in accordance with the component manufacturer's recommended procedures, or as modified during the contract through supplements. All internal parts of the components shall be the repair responsibility of the successful bidder, except maintenance adjustments.

The Contractor shall complete and provide the documentation entitled Specification Sheet for Delivery of PennDOT Vehicles to the following:

Email: Contact the Automotive Equipment Specialist @ The Equipment Division @ 717-783-1395 (This is an Excel Spread Sheet, a Work Copy will be Emailed to You)

Mail: Equipment Division

17th & Arsenal Blvd.

Harrisburg, Pa.17120

Attn: Specifications Division

Note: These Forms Must Be Delivered to The Equipment Division With The Pilot Model!

Instructions To Vendor For Completing The Attached Form

Electronic:

- 1 Obtain Work Copy By Calling 717-783-1395
- 2 All Sections Are to be Filled Out
- 3 Insert N/A in All Sections That Do Not Apply, Do Not Leave any Sections Blank
- 4 Manufacturer, Model No. And Part No. Should Reflect The Actual Component Manufacture
- 5 Warranty Section Should Reflect The Coverage, The Vendor And/Or Equipment (Truck) Manufacturer Will Supply, Not The Component Manufacturer.

Paper:

- 1 Same As Above, but Type or Print All Information

V.50 CONTRACT-047.2b General Requirements PennDOT Vehicles/Equipment PCID NO. 1067 (Oct 2006)

The Contractor must supply the contracted vehicles that are to be delivered to the Commonwealth of Pennsylvania in accordance with PCID 1075, which is attached to this IFB and made a part thereof.

V.51 CONTRACT-047.3 Monthly Purchase Reports (March 5, 2007)

The Contractor shall furnish to the Commonwealth monthly electronic reports no later than the fifteenth calendar

day of the month for the previous month's purchasing activity. Failure to provide this information may result in termination of the Contract. Each report shall indicate name and address of the Contractor, Contract number, and period covered by the report. The following information shall be listed on the report for each order received.

Item No.
Material Number
CWOPA Agency
Public Procurement Unit
Make
Model/Trim
Additional Options (above specifications)
Vehicle Cost (according to specifications)
Delivery Charge
Quantity
Order Date
Delivery Date

All such reports shall be created using a template provided by the Commonwealth. Final format and types of data requested will be agreed upon by the parties. Reports shall be sent to the Director, Bureau of Vehicle Management, Department of General Services and to the Bureau of Procurement, Department of General Services c/o the commodity specialist assigned to this contract.

V.52 CONTRACT-047.4 Quarterly Business Review Meetings (Oct 2006)

The Commonwealth requires that the Contractor and Original Equipment Manufacturer (OEM) actively participate in Quarterly Business Review meetings with the Commonwealth commodity manager and fleet manager to evaluate past performance, address any issues, discuss upcoming vehicle changes, identify additional cost savings opportunities, and report build-out dates.

V.53 CONTRACT-047.5 Local Public Procurement Unit Participation (March 5, 2007)

Any questions or problems pertaining to acquisition of vehicles by participating Local Public Procurement Units and their use of the Contract should be accomplished in a timely manner and all contact pertaining to these questions or problems should be directed to the Bureau of Procurement, Department of General Services to the attention of the commodity specialist assigned to this contract.

V.54 CONTRACT-047.6 Additional Delivery Charges (Participating Local Public Procurement Units ONLY) (Oct 2006)

Participating Local Public Procurement Units will pick up ordered equipment at the Contractor(s)'s place of business or have the equipment delivered by the Contractor for an additional **CHARGE PER VEHICLE of \$0.00** .

V.55 CONTRACT-047.7 Taxes (Oct 2006)

All participating Local Public Procurement Units will be required to indicate on their purchase orders the Internal Revenue Service Registration Number for exemption from Federal Excise Tax, if applicable.

V.56 CONTRACT-047.8 Pricing Options (Oct 2006)

When an end-user needs to price options that are in addition to the Commonwealth's minimum specifications found in Attachment D - Vehicle Specifications for an awarded vehicle on the Contract, the end-user will go to the Kelley Blue Book website at www.kbb.com to find the respective published invoice pricing. The invoice price for each additional option will be based upon the original date the Commonwealth or Local Public Procurement Units access the Kelly Blue Book website, referred to as the prep date on the Purchase Order. Additionally, the Contractor agrees to honor the price of the additional options as indicated on the prep date for a period of ten (10) days.

V.57 CONTRACT-051.1 Notice (Dec 2006)

Any written notice to any party under this Contract shall be deemed sufficient if delivered personally, or by

facsimile, telecopy, electronic or digital transmission (provided such delivery is confirmed), or by a recognized overnight courier service (e.g., DHL, Federal Express, etc.) with confirmed receipt, or by certified or registered United States mail, postage prepaid, return receipt requested, and sent to following:

- a. If to the Contractor: the Contractor's address as recorded in the Commonwealth's Supplier Registration system.
- b. If to the Commonwealth: the address of the Issuing Office as set forth on the Contract.